

## SECTION J

### THE STEERING GEAR

General Description.

Maintenance.

- |                  |   |
|------------------|---|
| Section No. J.1  | Removing and replacing the steering wheel.                              |
| Section No. J.2  | Removing and replacing the steering column.                             |
| Section No. J.3  | Removing and replacing the steering box.                                |
| Section No. J.4  | Removing and replacing the transfer box.                                |
| Section No. J.5  | Dismantling and reassembling the transfer box.                          |
| Section No. J.6  | Dismantling and reassembling the track- and tie-rods.                   |
| Section No. J.7  | Dismantling the steering gear.  |
| Section No. J.8  | Examining parts for wear.   |
| Section No. J.9  | Reassembling the steering gear.   |
| Section No. J.10 | Adjustments in position.  |
| Section No. J.11 | Adjusting wheel alignment.  |
| Section No. J.12 | Modified lock stops.  |
| Section No. J.13 | Track rod adjustment.   |
| Section No. J.14 | Removing the steering box on cars with modified front engine mountings. |
| Section No. J.15 | Modified steering box coupling.   |
| Section No. J.16 | Modified steering column.   |

#### GENERAL DESCRIPTION

The steering gear is of the cam and roller, two-pin type (from Car No. RMH.1170, one pin), in which the cam takes the form of a worm mounted on ball bearings in the steering box and connected to the steering mast by a splined coupling. The rocker-shaft is mounted in plain bearings; a lever integral with the shaft carries the conical pegs which engage with the cam. As the pegs do not bottom in the cam groove, adjustment for wear can be effected by adjusting the depth of engagement. This is carried out by means of the adjustment screw provided.

All the working parts are immersed in oil.

The steering drop-arm is attached to the shaft by parallel splines and a retaining nut, and is connected to a steering transfer box at the opposite side of the car.

The steering box drop-arm and the transfer box drop-arm are connected to a track-rod by spring-loaded

ball joints; each end of the track-rod is connected to the swivel pin steering arm by short tie-rods with ball-and-socket joint at the track-rod and steering arm.

#### MAINTENANCE

The filler plug provided on the steering gearbox should be removed every 3,000 miles (5000 km.) and the box topped up with oil to the level of the filler plug opening. Hypoid oil to Ref. B, page P.2, should be used. **Never use grease.**

Every 1,000 miles (1600 km.) a grease gun filled with grease to Ref. D, page P.2, should be applied to the nipple on the transfer box and given three or four strokes; at the same intervals the tie- and track-rod ball joints should also be lubricated.

Check that the steering arms and ball ends are tight and also that the bolts securing the gearbox and transfer box to the frame have not worked loose.

# J THE STEERING GEAR

## Section J.1

### REMOVING AND REPLACING THE STEERING WHEEL

Remove the three set screws and the top cover.

Remove the three set screws from the hub cover below the wheel.

Disconnect the horn and trafficator wires from the switch and trip mechanism.

Unscrew the central nut and pull the wheel from the mast.

To refit, reverse the above sequence.

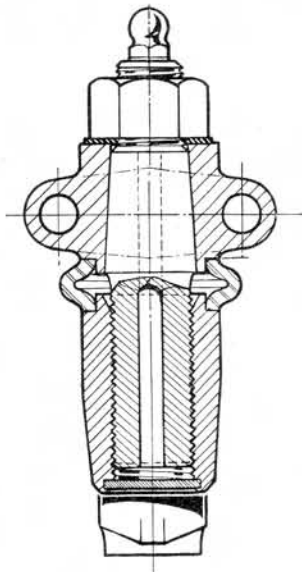

Fig. J.1.  
A section through  
the steering transfer  
box.

## Section J.2

### REMOVING AND REPLACING THE STEERING COLUMN

It is not necessary to remove the wheel.

Remove the hand brake and upper support bracket bolts.

Disconnect the wiring at the snap connectors below the fascia panel.

Lift the bonnet and unscrew the steering column adjustment clamp; slide the clamp down the column.

Remove the key from the column and pull the column up into the body.

## Section J.3

### REMOVING AND REPLACING THE STEERING BOX

Two methods are possible: the box may be disconnected at the coupling or at the sliding adjustment as detailed in the previous section.

To disconnect the coupling, extract the split pins and unscrew the three nuts and bolts.

Extract the split pin from the track-rod ball joint, unscrew the nut and tap the end of the drop-arm to free the joint from the taper.

Unscrew two nuts and two set bolts securing the box to the chassis.

Manoeuvre the box downwards from the car.

Replacement is a reversal of the above procedure, but replace the two halves of the coupling in the same relative positions or the Trafficator trip will not operate correctly.

## Section J.4

### REMOVING AND REPLACING THE TRANSFER BOX

Extract the split pin and unscrew the nut from the track-rod ball joint; tap the end of the steering arm to free the taper, and disconnect the ball joint from the steering arm.

Remove the one vertical and two horizontal set bolts securing the box to the frame and remove it from the car.

When refitting, clean the taper on the ball joint and in the steering arm.

## Section J.5

### DISMANTLING AND REASSEMBLING THE TRANSFER BOX

Screw out the greaser nipple.

Tap down the locking tab and unscrew the nut.

Tap the intermediate swivel pin from its taper hole in the housing.

Unscrew the steering arm from the transfer box swivel pin.

Reverse this sequence of operations to reassemble.

Screw the steering arm on to the pin as far as it will go and then unscrew it between one and one half turn, making sure that there is sufficient free movement to accommodate the range of movement necessary from lock to lock.

## Section J.6

### DISMANTLING AND REASSEMBLING THE TRACK- AND TIE-RODS

Extract the split pin from each of the four ball joint nuts.

Unscrew the nuts and tap the ends of the steering arms to free the ball joints from the tapered holes; remove the tie- and track-rods as an assembly.

Slacken the locknuts and screw the ball socket assemblies from the outer ends of the tie-rods.

Unscrew the retaining screw and remove the clip and circlip from the rubber boot covering each ball housing on the ends of the track-rod; remove the boots. Hold the track-rod in a vice and unscrew the ball seats with the special tool Part No. 300813. The shims and ball seats are now free.

Extract the outer springs from the track-rod.

Unscrew the track-rod ball joint grease retainer screws and withdraw the balls from the rod.

Extract the two inner springs and the four ball cups.

Reassembly is mainly a reversal of the above procedure, but replace the shims in the ball housings and check when tightened up. The ball must be a reasonably tight sliding fit without play. Shims are available in thicknesses of .002 in. and .003 in. for adjustment.

Clean all the tapers and taper holes before replacing.

## Section J.7

### DISMANTLING THE STEERING GEAR

Remove the gearbox as detailed in Section J.3.

Mark the drop-arm and the end of the shaft; knock up the locking tab and unscrew the nut; pull off the drop-arm.

Unscrew the six set bolts and remove the gearbox cover.

Withdraw the rocker-shaft.

Unscrew the central coupling nut and pull off the coupling.

Unscrew the set bolts and remove the end cover and shims.

Pull the cam and shaft, with bearing, oil seal and distance collar from the box.

Extract the end bearing.

## Section J.8

### EXAMINING PARTS FOR WEAR

Thoroughly clean the steering gearbox and examine the rocker-shaft housing and bush for wear. Examine the rocker-shaft on its shank for wear; if it is badly worn it should be renewed and a new bush and oil-retaining felt fitted. Check the splines; if they are twisted the rocker-shaft must be renewed. Examine the pegs for wear and slackness.

Examine the cam for excessive wear in the grooves, and also the ball tracks machined at each end of the cam for any signs of pitting. If the cam is defective for either of these reasons, the cam and steering mast must be renewed.

Examine the ball cups for pitting in the ball tracks.

## Section J.9

### REASSEMBLING THE STEERING GEAR

With all parts clean, replace the end bearing in the housing, followed by the cam, second ball race, oil seal and distance collar. Refit the shims and end cover.

Rotate the cam which should be free but without end play. If it is tight, shims must be added, and if there is any end play shims must be removed to give the correct setting.

Smear the rocker-shaft with hypoid oil and refit it to the box. Refit the cover and drop-arm and adjust the backlash as detailed in Section J.10.

Replace the gearbox in the frame and fill with hypoid oil to Ref. B, page P.2.

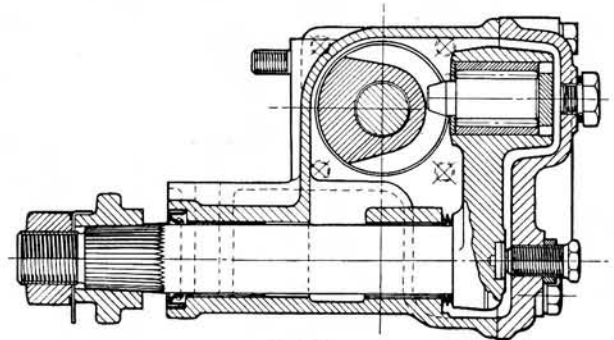

Fig. J.2.

A transverse section of the gearbox.

## Section J.10

### ADJUSTMENTS IN POSITION

Turn the steering wheel until the road wheels are in the straight-ahead position.

Disconnect the track-rod from the drop-arm and test for slackness by moving the drop-arm from side to side.

To eliminate backlash, slacken the locknut of the adjustment screw in the gearbox cover and tighten the thrust screw until all play is taken up. Tighten the locknut.

As the steering wheel is turned from lock to lock the degree of backlash at the end of the drop-arm is not the same at all steering positions, there being no backlash in the straight-ahead position and an increasing amount as the full-lock positions are reached.

If slackness is present at **all** positions of the steering further adjustment must be made until a high-spot is felt as the steering passes the straight-ahead position. When this high-spot can be felt as a very slight drag on the steering wheel the adjustment is correct.

**Note.**—Care must be taken not to alter the setting of the thrust screw while the locknut is being tightened up.

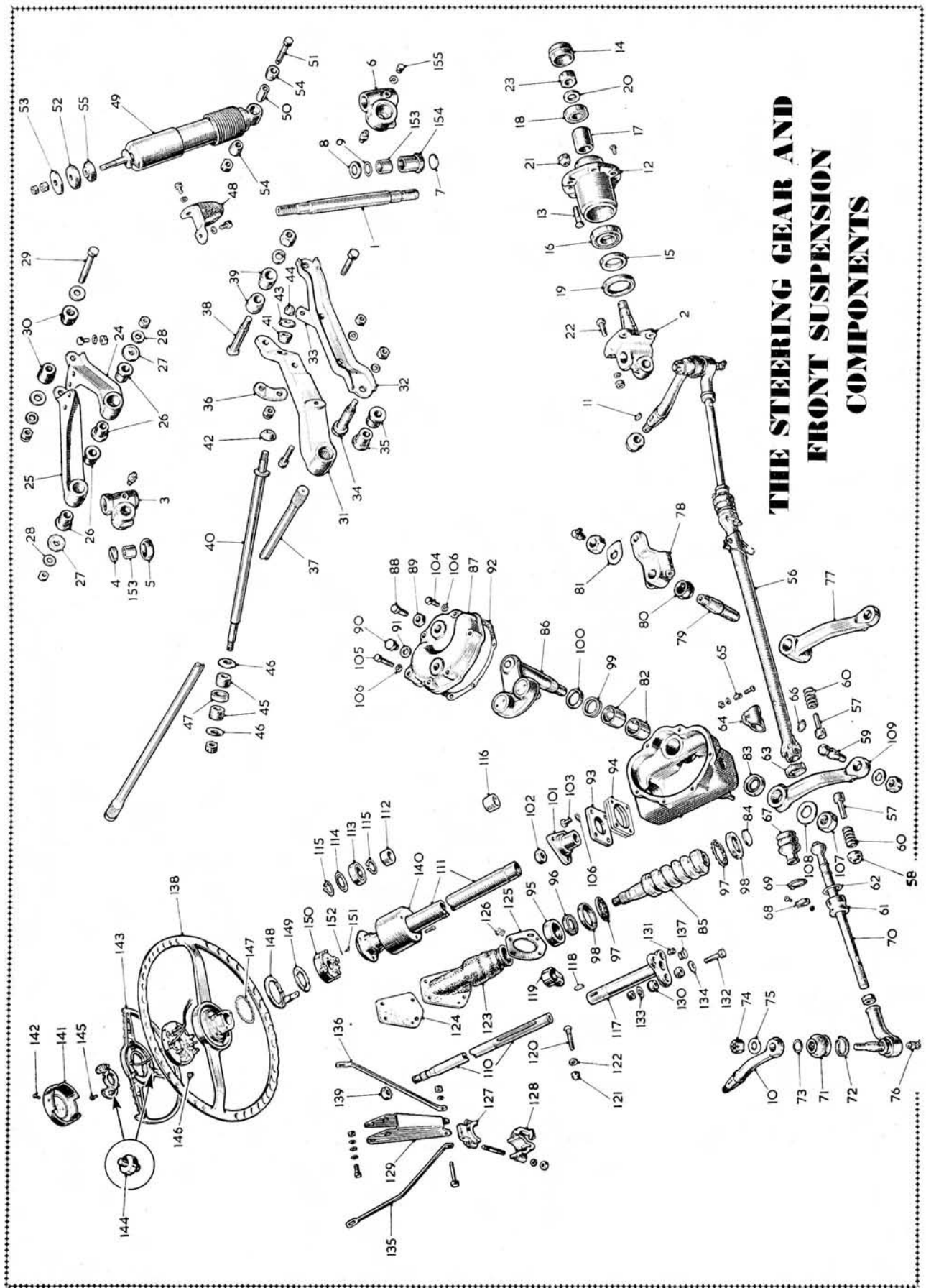

**THE STEERING GEAR AND  
FRONT SUSPENSION  
COMPONENTS**

## KEY TO THE STEERING GEAR AND FRONT SUSPENSION COMPONENTS

No.	Description	No.	Description	No.	Description
1.	Pin—swivel—L/H.	53.	Washer—top—shock absorber.	105.	Bolt—cover—side.
2.	Axle—stub—L/H.	54.	Bush.	106.	Washer—spring—side and end cover bolts.
3.	Link assembly—swivel pin—top—L/H.	55.	Rod—shock absorber stem fixing.	107.	Nut—drop-arm.
4.	Plug—swivel pin link.	56.	Rod—track assembly.	108.	Washer—lock—drop-arm nut.
5.	Seal—swivel pin link top.	57.	Seat—ball—inner.	109.	Arm—steering drop (RHD).
6.	Link assembly—swivel pin—lower—L/H.	58.	Seat—ball—outer.	110.	Tube—steering.
7.	Plate—swivel pin link—lower.	59.	Pin—ball.	111.	Tube—outer assembly.
8.	Seal—swivel pin link—lower.	60.	Spring—ball pin.	112.	Retainer—oil.
9.	Ring—seal retaining.	61.	Housing—ball.	113.	Ball race.
10.	Lever—steering—R/H.	62.	Shim—ball joint.	114.	Plate—ball race cover.
11.	Key—Woodruff.	63.	Cap—locking—ball housing.	115.	Circlip.
12.	Hub assembly (studded)—front.	64.	Retainer—grease.	116.	Bush felt.
13.	Stud—wheel.	65.	Spacer—grease retainer.	117.	Flange—coupling.
14.	Cup—grease retaining.	66.	Nipple—grease.	118.	Key—flange coupling.
15.	Washer—hub distance.	67.	Seal—ball housing.	119.	Clamp—flange coupling.
16.	Bearing—hub—inner.	68.	Clip—ball housing seal.	120.	Bolt—flange coupling clamp.
17.	Spacer—hub bearing.	69.	Circlip—ball housing seal.	121.	Nut—clamp bolt.
18.	Bearing—hub outer.	70.	Rod—tie.	122.	Washer—clamp bolt.
19.	Seal—oil—hub bearing.	71.	Excluder—dust.	123.	Seal—steering column.
20.	Washer—hub bearing.	72.	Clip—dust excluder (large).	124.	Seal—blank.
21.	Nut for road wheel.	73.	Clip—dust excluder (small).	125.	Plate—seal.
22.	Bolt—brake plate and stub shaft.	74.	Nut—slotted—ball pin.	126.	Nut—speed fix.
23.	Nut—hub bearing.	75.	Washer—ball pin nut.	127.	Clamp—steering column—upper half.
24.	Link—upper—front—L/H.	76.	Nipple—grease.	128.	Clamp—steering column—lower half.
25.	Link—upper—rear—L/H.	77.	Arm—intermediate steering.	129.	Bracket—steering column support.
26.	Bush—upper link.	78.	Bracket—intermediate steering arm.	130.	Bearing—steering column.
27.	Washer—cup—upper link.	79.	Pin—swivel—intermediate steering arm.	131.	Tube—spacer—bearing.
28.	Tab washer.	80.	Seal—dust—swivel pin.	132.	Bolt.
29.	Bolt—upper link.	81.	Lock washer—swivel pin nut.	133.	Washer—thin.
30.	Bush—lined—upper link.	82.	Bush.	134.	Washer—thick.
31.	Arm—lower—rear.	83.	Seal—oil—drop-arm aperture.	135.	Strut—steering column support (RHD).
32.	Arm assembly—lower—front—L/H.	84.	Welch plug (RHD).	136.	Strut—inner—steering column support.
33.	Bracket—shock absorber mounting—front.	85.	Cam and shaft assembly (RHD).	137.	Spring—steering column connector.
34.	Extension—lower arm.	86.	Shaft assembly—rocker (RHD).	138.	Wheel—steering.
35.	Bush.	87.	Cover—side.	139.	Nut—steering wheel.
36.	Bracket—shock absorber mounting—rear—L/H.	88.	Screw—thrust.	140.	Hub—lower—steering wheel.
37.	Bar—torsion.	89.	Nut—lock—thrust screw.	141.	Cover and motif.
38.	Bolt—trunnion—lower.	90.	Plug—oil.	142.	Screw—cover fixing.
39.	Bush—trunnion—lower.	91.	Washer—oil plug.	143.	Ring—Trafficator and horn control.
40.	Bar—tie.	92.	Joint (gasket).	144.	Rollers.
41.	Bush—tie-bar—front.	93.	Cover—end (RHD).	145.	Screw—adjusting bracket fixing.
42.	Bush—spherical—tie-bar.	94.	Shim.	146.	Bush—adjusting bracket fixing screws.
43.	Washer—tie-bar—front.	95.	Distance-piece.	147.	Washer—corrugated.
44.	Nut—tie-bar—front.	96.	Seal—oil—steering column aperture.	148.	Washer—large with tab.
45.	Bush—tie-bar—rear.	97.	Ball cage assembly.	149.	Washer—retaining.
46.	Washer—cup—tie-bar—rear.	98.	Cup—ball.	150.	Slip ring—complete.
47.	Retainer—bush—tie-bar.	99.	Belleisle washer—rocker-shaft.	151.	Screw—slip ring to steering wheel.
48.	Bump rubber.	100.	Washer—thrust.	152.	Washer—slip ring to steering wheel.
49.	Shock absorber.	101.	Coupling—flange.	153.	Bush—swivel pin link.
50.	Tube—distance—shock absorber.	102.	Nut—lock—flange coupling.	154.	Bush (screwed)—swivel pin link—lower—R/H.
51.	Bolt—shock absorber lower eye.	103.	Bolt—cover—end.	155.	Screw—screwed bush retaining.
52.	Bush—top—shock absorber.	104.	Bolt—cover—side (short).		

# J THE STEERING GEAR

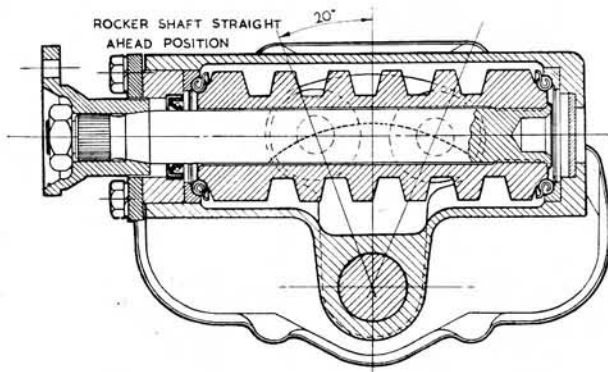

Fig. J.3.

A longitudinal section through the steering cam. In later models, the 20° angle has been changed to 21½°. From Car No. RMH.1170, one pin only is used.

## Section J.11

### ADJUSTING WHEEL ALIGNMENT

When correctly adjusted the front wheels should be parallel to each other in the straight-ahead position. To carry out any adjustment first inflate the tyres to the standard pressure indicated in General Data.

Where modern wheel alignment equipment is available this will present no difficulty, but when this is not available the trammel method must be used.

Turn the wheels to their straight-ahead position and position the pointers of a set of alignment trammels to the wheel centre height.

Place the trammel at the rear of the front wheels and adjust it longitudinally so that both pointers register against the outside rim of each wheel. Mark the position of the pointers on each wheel rim, with chalk, withdraw the trammel and push the car forward so that the wheels make exactly half a revolution.

Move the trammel to the front of the wheel, so that one pointer registers with the chalk mark on one of the wheels. For correct alignment, the other pointer should register against the mark on the other wheel.

Should it not do so, adjust the track by slackening the locknut at the end of the tie-rod and then rotating

the tie-rods in the necessary direction with a spanner applied to the flats provided. Both tie-rods should be adjusted equally and be of the same length when adjustment is completed.

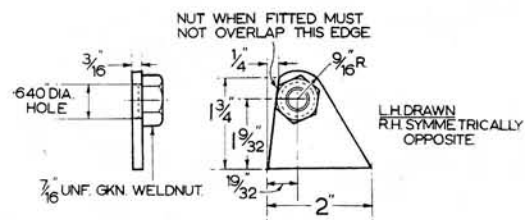
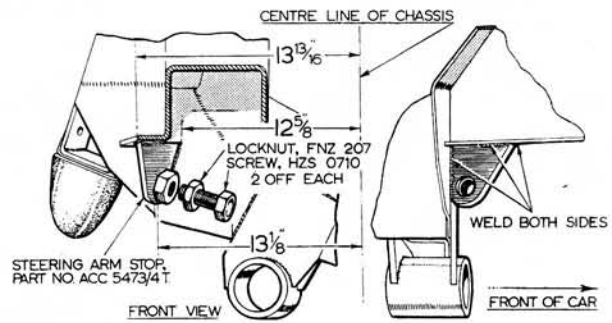

Fig. J.4.

The new type of lock stop.

## Section J.12

### MODIFIED LOCK STOPS

A new type of lock stop is now fitted, and cars may be modified in accordance with Fig. J.4.

## Section J.13

### TRACK-ROD ADJUSTMENT

In earlier models the track-rod ends were adjusted to give an overall clearance up to a maximum of .040 in. This should be reduced to a maximum of .010 in.

If necessary, shims must be fitted between the inner ends of the inner track-rod springs to give an overall clearance of .004 in. to .010 in. at each end of the track-rod. Shims are available in thicknesses of .005 in. and .010 in.

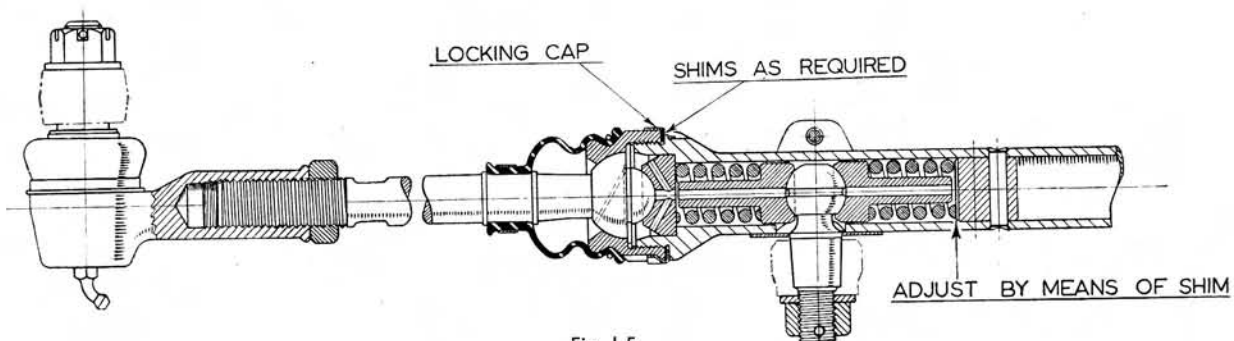

Fig. J.5.

Track-rod adjustment points.

**Section J.14**

**REMOVING THE STEERING BOX ON CARS WITH MODIFIED FRONT ENGINE MOUNTINGS**

Remove the radiator as detailed in Section D.2.

Undo the nuts (upper and lower) from the engine front mountings.

Lift the front of the engine, remove the four nuts and spring washers securing the front engine mounting plate to the engine timing case and remove the plate. Undo the four bolts securing the front engine mounting bracket on the driver's side of the car and remove the bracket.

The steering box may then be removed as detailed in Section J.3.

**Section J.15**

**MODIFIED STEERING BOX COUPLING**

Commencing at Car No. 5285, L.H.D. only, a modified steering box coupling is introduced. The new coupling has tapped holes instead of plain and the three nuts and bolts are replaced by shorter bolts secured with a locking washer.

The coupling may be fitted to earlier steering boxes together with the shorter bolts.

The new part numbers are:—

Coupling	Part No. 7H.6578
Bolt (3 off)	Part No. HBZ.5012
Locking washer	Part No. ACC.5560

**Section J.16**

**MODIFIED STEERING COLUMN**

Commencing at Car No. 5462, a modified steering column assembly is fitted. The steering column adjustment clamp is replaced by a key retaining ring and circlip and the dipswitch leads are enclosed in a tube attached to the steering column outer assembly tube.

Adjustment of steering wheel height with the later column is carried out by slackening the two steering column clamp nuts below the fascia panel and the nut on the steering column support bracket. Removal instructions remain as before with the exception that it is now necessary to remove the key retaining ring circlip and slide the retaining ring up the steering column instead of releasing the adjusting clamp.

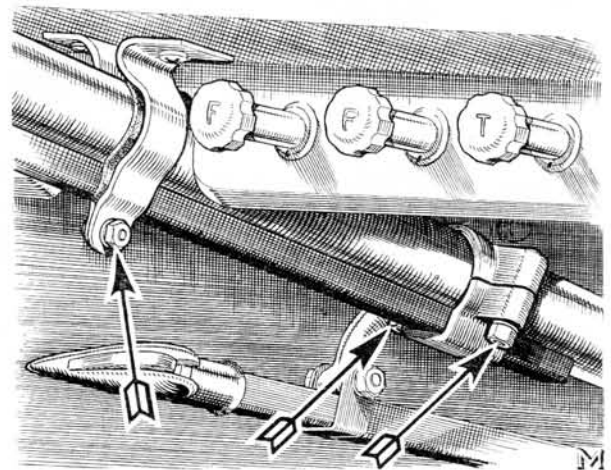

Fig. J.6.

It is possible to adjust the position of the steering column by slackening the three nuts indicated in this illustration.