

## **SECTION C**

### **THE IGNITION EQUIPMENT**

General Description.

- Section No. C.1    Testing for the cause of uneven firing.
- Section No. C.2    Testing the low-tension circuit.
- Section No. C.3    The high-tension cables.
- Section No. C.4    Servicing the sparking plugs.
- Section No. C.5    The contact breaker.
- Section No. C.6    Distributor lubrication.
- Section No. C.7    Removing and replacing the distributor.
- Section No. C.8    Ignition timing.
- Section No. C.9    Dismantling the distributor.
- Section No. C.10   The capacitor.
- Section No. C.11   Reassembling the distributor.

# THE DISTRIBUTOR AND HIGH-TENSION CARRIER TUBE

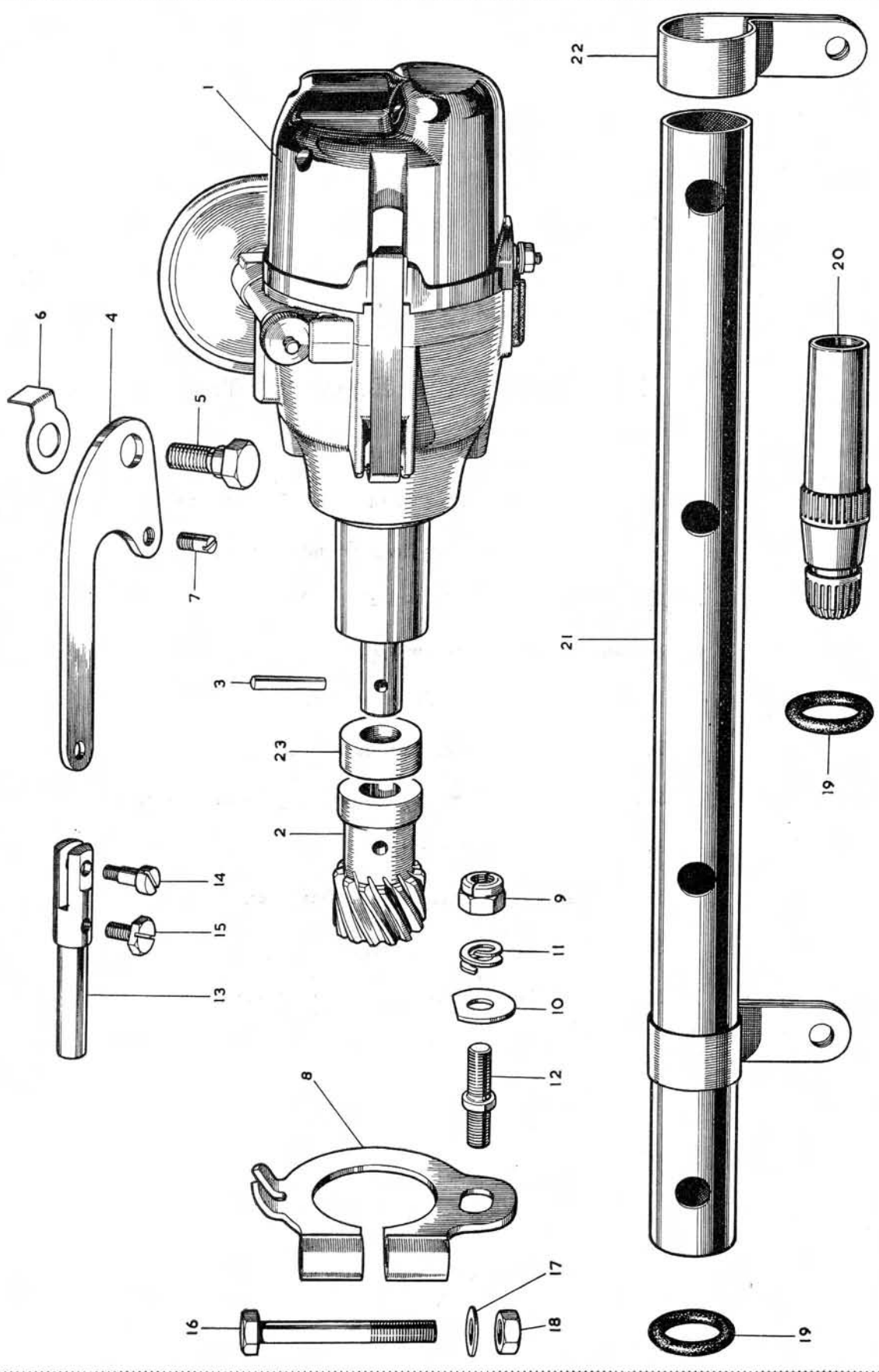

### KEY TO THE DISTRIBUTOR AND HIGH-TENSION CARRIER TUBE

No.	Description	No.	Description	No.	Description
1.	Distributor.	9.	Nut—distributor control lever.	17.	Washer—clamp bolt.
2.	Pinion—distributor.	10.	Washer—plain—distributor control lever.	18.	Nut—clamp bolt.
3.	Pin—taper—distributor pinion.	11.	Washer—spring—distributor control lever.	19.	Ring—high-tension cables.
4.	Arm—distributor control.	12.	Stud—distributor lever.	20.	Terminal—sparking plug suppressor.
5.	Bolt—pivot—distributor control arm.	13.	Jaw—distributor control.	21.	Tube—high-tension cables.
6.	Tab washer—distributor control arm.	14.	Screw—distributor control jaw link.	22.	Clip—high-tension cable tube.
7.	Pin—link—distributor control arm.	15.	Screw—distributor control jaw cable.	23.	Distance-piece—distributor.
8.	Lever—distributor control.	16.	Screw—clamp.		

# C THE IGNITION EQUIPMENT

## GENERAL DESCRIPTION

Ignition is by coil and distributor with vacuum and centrifugal automatic advance mechanism. A manual advance is also incorporated.

### Distributor

Lucas type DM.2, service number 40419.A.

### Coil

Lucas Model B.12/1. Identification marks are stamped on the base of the coil.

### Sparking Plugs

Champion NA.8, 14 mm.  $\times \frac{3}{4}$  in. reach. Gap : .025 in. (.63 mm.).

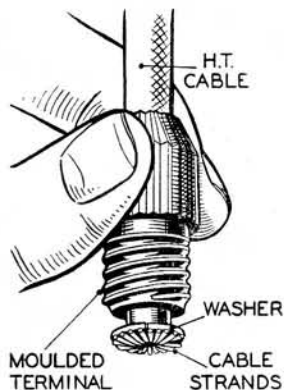

Fig. C.1.

The correct method of fitting a high-tension lead to the ignition coil terminal nut.

## Section C.1

### TESTING WITH SPARKING PLUGS IN POSITION TO LOCATE THE CAUSE OF UNEVEN FIRING

*Test in position to locate cause of uneven firing*

- Start the engine and set it to run at a fairly fast idling speed.
- Short-circuit each plug in turn by placing a hammer head or the blade of a wooden-handled or insulated-type screwdriver between the terminal and the cylinder head. No difference in the engine performance will be noted when short-circuiting the plug in the defective cylinder. Shorting the other plugs will make uneven running more pronounced.
- Having located the cylinder which is at fault, stop the engine and remove the cable from the terminal of the sparking plug. Restart the engine and hold the end of the cable about  $\frac{3}{16}$  in. from the cylinder head.

- If the sparking is strong and regular, the fault probably lies in the sparking plug. Remove the plug, clean and adjust the gap to the correct setting or alternatively fit a replacement plug.
- If there is no spark or if it is weak and irregular, examine the cable from the sparking plug to the distributor. After a long period of service the rubber insulation may be cracked or perished, in which case the cable should be renewed. Finally, examine the distributor moulded cap, wipe the inside and outside with a clean dry cloth, see that the carbon brush moves freely in its holder and examine the moulding closely for signs of breakdown. After long service it may have become tracked, that is, a conducting path may have formed between two or more of the electrodes or between one of the electrodes and some part of the distributor in contact with the cap. Evidence of a tracked cap is shown by the presence of a thin black line in the places indicated. A replacement distributor cap must be fitted in place of one that has become tracked.

## Section C.2

### TESTING THE LOW-TENSION CIRCUIT

*Testing in position. Low-tension circuit*

- Spring back the securing clips on the distributor and remove the moulded cap and rotor. If the rotor is a tight fit, it can be levered off carefully with a screwdriver.
- Check that the contacts are clean and free from pits, burns, oil and grease. Turn the engine and check that the contacts are opening and closing correctly and that the clearance when the contacts are fully opened is between .014 in. and .016 in. (.36 mm. and .40 mm.).
- Switch on the ignition, turn the engine with the starting handle and observe the ammeter reading, which should rise and fall with the closing and opening of the contacts. If the reading fluctuates in this way, the low-tension circuit is in order.
- If the ammeter reading remains steady, locate the fault in the low-tension circuit.
- Another method of testing is to disconnect the cable at the contact breaker terminal of the coil and at the low-tension terminal of the distributor, and connect a test lamp between these terminals. If the lamp lights when the contacts close and goes out when the contacts open, the low-tension circuit is in order.

*Low-tension circuit—to locate fault.*

- (a) Having determined, by testing as previously described, that the fault lies in the low-tension circuit, switch on the ignition and turn the engine until the contact breaker points are fully opened.
- (b) Check the circuit with a voltmeter (0—20 volts) as follows :—  
**Note.**—If the circuit is in order the reading on the voltmeter should be approximately 12 volts.
- (c) *Battery to starter switch.* Connect voltmeter to starter switch terminal and to earth. No reading indicates faulty cable or loose connections.
- (d) *Starter switch to ammeter (brown lead).* Connect a voltmeter to the ammeter terminal and to earth. No reading indicates faulty cable or loose connections.
- (e) *Ammeter.* Connect a voltmeter to the other ammeter terminal and to earth. No reading indicates a fault in the ammeter, which must be renewed.



Fig. C.2.

This illustration shows plug gaskets in various conditions —(1) Indicating insufficient tightening down of the plug. (2) Over-tightening of the plug. (3) Correct degree of tightening. (4) New gasket before use.

- (f) *Ammeter to control box terminal "A" (brown with white).* Connect a voltmeter to the control box terminal "A" and to earth. No reading indicates a faulty cable or loose connections.
- (g) *Control box.* Connect a voltmeter to the control box terminal "A1" and to earth. No reading indicates a fault in the series winding of the control box.
- (h) *Control box "A1" to ignition switch (brown with blue).* Connect a voltmeter to the ignition switch terminal and to earth. No reading indicates a faulty cable or loose connections.

- (i) *Ignition switch.* Connect a voltmeter to the other ignition switch terminal (white lead) and to earth. No reading indicates a fault in the ignition switch.
- (j) *Ignition switch to fuse box terminal "A3" (white lead).* Connect the voltmeter to the fuse box terminal "A3" and to earth. No reading indicates a faulty cable or loose connections.
- (k) *Fuse box terminal "A3" to ignition coil terminal "SW" (white lead).* Connect a voltmeter to the ignition coil terminal "SW" and to earth. No reading indicates a faulty cable or loose connections.
- (l) *Ignition coil.* Connect a voltmeter to the ignition coil terminal "CB" and earth. No reading indicates a fault in the primary winding of the coil.
- (m) *Ignition coil to distributor (white with black lead).* Disconnect the low-tension cable to the distributor and connect the voltmeter between the end of the cable removed and earth. No reading indicates a faulty lead or loose connection. Reconnect the cable to the distributor.
- (n) *Contact breaker and condenser.* Connect the voltmeter across the contact breaker points. No reading indicates a fault in the condenser.

## Section C.3

### THE HIGH-TENSION CABLES

- (a) The high-tension cables must be examined carefully and any which have the insulation cracked, perished or damaged in any way must be replaced by 7 mm. cable.

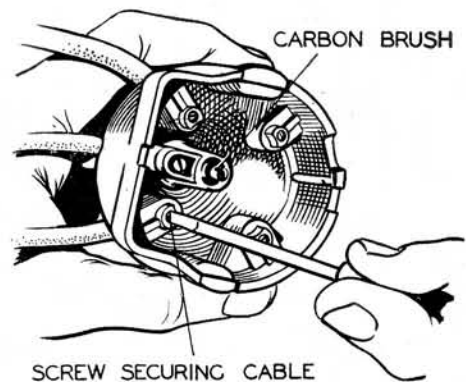

Fig. C.3.

Securing an H.T. cable to the distributor cap.

# C THE IGNITION EQUIPMENT

- (b) To fit new high-tension cables thread the knurled moulded terminal nut over the lead, bare the end of the cable for about  $\frac{1}{4}$  in., thread the wire through the brass washer removed from the original cable and bend back the strands over the washer. Finally screw the nut into its terminal.
- (c) The cables from the distributor to the sparking plugs must be connected up in the correct firing order, which is 1, 2, 4, 3.

## Section C.4

### SERVICING THE SPARKING PLUGS

It is recommended that the plugs be inspected, cleaned and tested very 3,000 miles (5000 km.).

When sparking plugs are removed from the engine their gaskets should be removed with them and replaced on the plugs, which should be placed in a suitable holder. It is advisable to identify each plug with the number of the cylinder from which it was removed so that any faults revealed on examination can be traced back to the cylinder concerned.

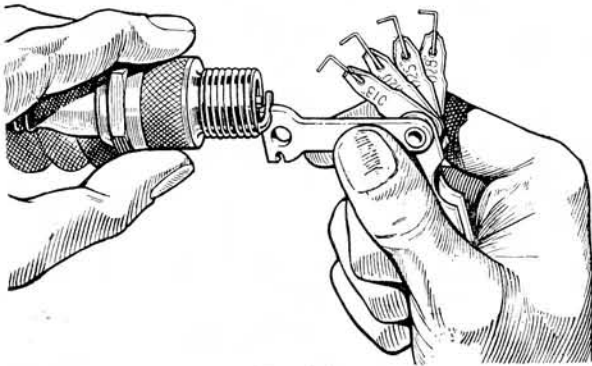

Fig. C.4.

Illustrating the use of the "Champion" plug setting tool.

When examining the plugs, place a new plug of the same type beside the others to afford a ready comparison of the relative condition of the used plugs.

Examine for signs of oil fouling. This will be indicated by a wet, shiny, black deposit on the insulator. This is caused by oil pumping due to worn cylinders and pistons, or gummed-up or broken rings. Under such conditions, oil from the cylinder walls is forced up past the rings on the suction stroke of the piston, and is eventually deposited on the plugs.

A permanent remedy for this cannot be effected, the only cure being the fitting of a new piston and rings, or, in extreme cases, a rebore may be necessary.

Next examine the plugs for signs of petrol fouling. This is indicated by a dry, fluffy, black deposit which is usually caused by over-rich carburation, although ignition system defects such as a run-down battery, faulty distributor, coil or condenser defects, or a broken or worn-out cable, may be additional causes. The important thing is for the carburetter setting to be correctly adjusted and the ignition system overhauled as indicated in Sections C.3 and C.5. If the plugs appear to be suitable for further use, proceed to clean and test them.

First remove the plug gaskets and examine them for condition. Gaskets in different conditions are illustrated in Fig. C.2. The upper left gasket was obviously not properly compressed, owing to the plug not having been tightened down sufficiently. A large proportion of the heat of the plug is normally dissipated to the cylinder head through the copper gasket between the plug and the head. Plugs not screwed down tightly can thus easily become overheated so that they operate out of their proper heat range, thus producing pre-ignition, short plug life and "pinking." On the other hand it is unnecessary and unwise to tighten up the plugs too much. What is required is a reasonably good seal between the plug and the cylinder head.

The lower left-hand gasket clearly indicates that the plug was pulled down too tightly or has been in service too long. Note its distorted condition and the evidence of blow-by, which is also a cause of plug overheating.

The upper right-hand gasket demonstrates a gasket in good condition, providing an adequate seal and a good path for heat dissipation.

For comparison a new gasket is shown at the lower right-hand corner of Fig. C.2. If gaskets are at all questionable they should be replaced by new ones without hesitation.

If the plugs require cleaning it is preferable to make use of a proper plug cleaner of the type recommended by the plug manufacturers, and the makers' instructions for using the cleaner should carefully be followed out.

Occasionally a blistered insulator or a badly burnt electrode may be noticed when examining the plugs.

If the plug is of the type normally recommended for the engine and it was correctly installed (down tightly on the gasket), this condition may have been brought about by a very lean mixture or an overheated engine. There is, however, a possibility that a plug of another type is required, but as a rule the Champion plug recommended should be adhered to.

After cleaning carefully, examine the plugs for cracked insulators and wear of the insulator nose due

to excessive previous cleaning. In such cases the plugs have passed their useful life, and new plugs should be installed.

Examine the insulator for deposits underneath the side electrode which have possibly accumulated and which act as a "hot spot" in service.

After cleaning the plugs in the special cleaner, blow all surplus abrasive out of the body recesses and off the plug threads by means of an air-blast. Next examine the threads for carbon. Any deposits can be removed and the threads cleaned with a wire brush. A wire buffing wheel may also be utilised, but reasonable care must be used in both methods in order not to injure the electrodes or the tip of the insulator. The thread section of the plug body is often neglected when cleaning the plugs, owing to the fact that it is not generally realised that, like the gaskets, the threads are a means of heat dissipation and that when they are coated with carbon it retards the flow of the heat from the plug, producing overheating. This simple procedure will also ensure absence of binding on the threads on replacement and also avoid the unnecessary use of the plug spanner.

When replacing a plug, always screw it down by hand as far as possible and use the spanner for final tightening only. Whenever possible use a box spanner to avoid possible fracture of the insulator.

Examine the electrodes for correct gap. Avoid incorrect reading in the case of badly pitted electrodes.

Remember that electrode corrosion and the development of oxides at the gap area vitally affects the sparking efficiency. The special cleaner can remove the oxides and deposits from the insulator, but the cleaner stream does not always reach this area with full effect owing to its location, and cannot necessarily deal with corrosion effectively as this sometimes requires too strong a blast for proper removal.

When plugs appear worthy of further use it is good practice to dress the gap area on both centre and side electrodes with a small file before resetting them to the correct gap. The intense heat, pressure, explosion shock, electrical and chemical action to which the plugs are submitted during miles of service are so intense that the molecular structure of the metal points is eventually affected. Plugs then reach a worn-out condition and resetting the points can no longer serve a good purpose. When points are burnt badly, it is indicative that the plug has worn to such an extent that its further use is undesirable and wasteful.

Before replacing the plug in the engine, test it for correct functioning under air pressure in a plug tester, following out the instructions issued by the makers of the plug tester. Generally speaking, a plug

may be considered satisfactory for further service if it sparks continuously under a pressure of 100 lb. per sq. in. (7 kg./cm.<sup>2</sup>) with the gap between the points set at .025 in. (.64 mm.).

While the plug is under pressure in the tester it should be inspected for leakage by applying oil round the terminal. Leakage is indicated by the production of air bubbles, the intensity of which will serve to indicate the degree of leakage. The leakage gases have a "blow-torch" effect when the engine is running which rapidly raises the temperature of the plug, raising it above its designed heat range, thus producing overheating, pre-ignition, and rapid electrode destruction.

The top half of the insulator is frequently responsible for poor plug performance due to the following faults: splashes; accumulation of dirt and dust; cracked insulators, caused by a slipping spanner; over-tightness of the terminals.

Examine for a cracked insulator at the shoulder and the terminal post and remove any accumulation of dirt and dust.

## Section C.5

### THE CONTACT BREAKER MECHANISM

After the first 500 miles (800 km.) and subsequently every 3,000 miles (5000 km.) check the contact breaker as follows:—

(a) Turn the engine until the contact breaker points are fully opened, and check the gap with a gauge having a thickness of from .014 in. to .016 in. (.36 mm. to .40 mm.). If the gap is correct, the gauge should be a sliding fit. Do not alter the setting unless the gap varies considerably from the gauge thickness.

To adjust the setting, keep the engine in the position which gives maximum opening of the contacts and then slacken the two screws, securing the fixed contact plate. Adjust the position of the plate until the gap is set to the thickness of the gauge and then tighten the two locking screws.

(b) If the contacts are dirty or pitted, they must be cleaned by polishing them with a fine carborundum stone, and afterwards wiping them with a petrol-moistened cloth. The moving contact can be removed from its mounting in order to assist cleaning. Check and adjust the contact breaker setting after cleaning the contacts.

(c) Check that the moving arm moves freely on its pivot. If it is sluggish, remove the moving

# C THE IGNITION EQUIPMENT

arm and polish the pivot pin with a strip of fine emery cloth. Afterwards apply a spot of clean engine oil or grease to Ref. D (page P.2) to the top of the pivot. See Section P.

## Section C.6

### DISTRIBUTOR LUBRICATION

To be carried out after servicing the distributor and at intervals of about 3,000 miles (5000 km.).

- (a) Give the cam a light smear of grease to Ref. D (page P.2) and apply a slight trace of oil to the top of the pivot pin on which the contact breaker lever works.
- (b) Lift the rotor arm off the top of the spindle and add a few drops of thin oil to Ref. F (page P.2) through the lubricating passage provided in the spindle to lubricate the cam bearing and distributor shaft. (Do not remove the screw in the top of the spindle as an oilway is provided.) Refit the rotor correctly and push it on the shaft as far as it will go.
- (c) Add a few drops of thin oil to Ref. F (page P.2) through the aperture in the contact breaker base round the cam in order to lubricate the automatic timing control. Do not allow any oil to get on or near the contacts.

## Section C.7

### REMOVING AND REPLACING THE DISTRIBUTOR

The distributor, which has a centrifugal, suction and hand control advance is fitted on the right-hand side of the engine and retained by a slotted clamp plate with a spring-loaded retaining bolt screwed into the boss.

To remove the unit, detach the distributor head and undo the L.T. cable from the distributor to coil.

Undo the spring-loaded retaining nut.

Do not slacken the pinch bolt which contracts the clamp plate to the distributor body or the timing will be lost.

Before removing the distributor, make sure that the rotor arm is pointing to the segment in the cover for one particular cylinder. It is usual to choose the segment for the plug lead to No. 1 cylinder.

Lift the distributor away from the cylinder block, noting that the rotor will turn a certain amount due to the helical gear drive from the camshaft.

Provided that the engine is not turned, the distributor may be replaced in the same position so that the rotor arm is returned to the correct position as the distributor and camshaft gears mesh with each other.

Make sure that the pin on the manual advance lever is engaged in the fork of the distributor clamp plate.

Replace the retaining nut.

Final adjustments may be carried out on the road by slackening the distributor clamp pinch bolt and moving the distributor unit as desired. Do not forget to retighten the clamp bolt.

## Section C.8

### IGNITION TIMING

The ignition timing required varies according to the condition of the engine and the fuel used and can only be determined by actual road test.

The ignition timing also varies slightly with different engines and the correct procedure is to set the spark in accordance with the following method and adjust as required on the road.

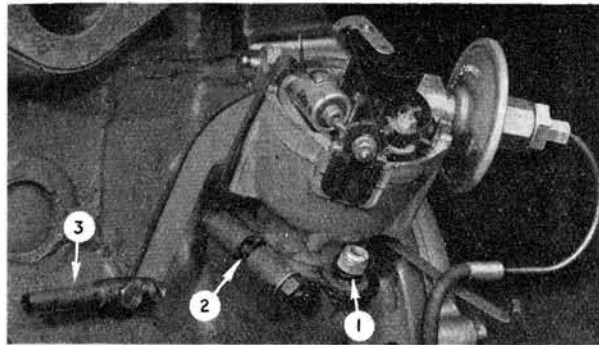

Fig. C.5.

The location and fitting of the distributor.

1. The distributor securing nut.
2. The clamp bolt : timing may be adjusted by slackening the bolt and turning the distributor head in the appropriate direction.
3. The manual advance and retard lever.

To obtain the correct timing the distributor contact points must be set to a clearance of .014 in. to .016 in. (.36 mm. to .40 mm.), after which the distributor head must be set so that the points just break at 4° to 8° B.T.D.C. with the hand ignition control fully advanced (pushed right in at the panel).

No timing marks are visible and the method of determining the correct piston position is to use a sliding plunger in conjunction with a dial gauge. This unit screws into the sparking plug hole and the piston travel may be measured accurately.

Four degrees from T.D.C. equals  $\cdot 0075$  in. ( $\cdot 19$  mm.) of piston travel and eight degrees equals  $\cdot 030$  in. ( $\cdot 76$  mm.).

**Important.**—To ensure an accurate setting of the distributor points an electrical method should be used.

With the low-tension lead connected to the distributor, turn on the ignition switch and connect a 12-volt lamp in parallel with the contact breaker point (i.e. one lead from the L.T. terminal and the other to earth) and turn the distributor slowly until the lamp lights ; this indicates the correct position for the distributor. If the engine has been set as indicated above, then the timing is correct.

Alternatively a second operator can watch the ammeter, which will flick back to zero when the points open.

## Section C.9

### DISMANTLING THE DISTRIBUTOR

(Before dismantling carefully note the positions in which the various components are fitted so that they can be replaced correctly.)

- (a) Spring back the securing clips and remove the moulded cap.
- (b) Lift the rotor from the top of the spindle. If it is a tight fit, it should be levered off carefully with a screwdriver.
- (c) Slacken the nut on the terminal post and lift off the end of the contact breaker spring. Lift the contact breaker lever off its pivot pin. Take out the two screws, complete with spring washers and flat steel washers, from the plate carrying the fixed contact and remove the plate.
- (d) Undo the two screws fitted at the edge of the contact breaker base and lift them out together with the spring washers. The contact breaker base can then be removed from the body of the distributor.
- (e) Unscrew the terminal nut, lift off the spring washer and remove the connector strip.
- (f) Drive out the taper pin passing through the driving gear and then press the shaft out of the gear.
- (g) Lift the cam, automatic timing control and shaft assembly from the distributor. Take out the screw from inside the top of the cam spindle and lift the cam off. The automatic timing control is then accessible.

## Section C.10

### THE CAPACITOR

The best method of testing the capacitor is by substitution. Disconnect the original capacitor and connect a new one between the low-tension terminal of the distributor and earth.

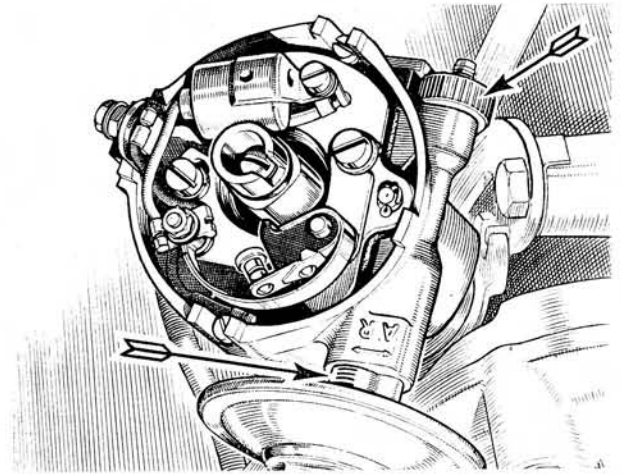

Fig. C.6.

Fine timing adjustment is obtainable by turning the knurled nut.

## Section C.11

### REASSEMBLING THE DISTRIBUTOR

**Note.**—Before reassembly, the automatic advance mechanism, distributor shaft, and the portion of the shaft on which the cam fits must be lubricated with thin, clean engine oil.

- (a) Assemble the automatic timing control, taking care that the parts are fitted in their original positions and that the control springs are not stretched. Two holes are provided in each toggle ; the springs must be fitted to the inner hole in each case. Place the cam on its spindle and secure by tightening the locking screw.
- (b) Fit the shaft in its bearings and replace the driving member. Remembering that the small offset of the driving tongue lies towards the front of the engine when the slot for the rotating arm in the cam faces towards the centre of the engine (or towards the condenser in the distributor body) fit the driving pin and burr over the collar each side, to retain it in position, with a suitable punch.

# C THE IGNITION EQUIPMENT

---

- (c) Place the contact breaker base in position on the distributor body and secure it by replacing the two screws. A spring washer must be fitted under each of the screw heads, and the screws must be fully tightened.
- (d) Place the end of the connector strip over the condenser terminal post, refit the spring washer and secure it by tightening the terminal nut.
- (e) Position the plate carrying the fixed contact on the contact breaker base and secure it by replacing and lightly tightening the two screws, placing a spring washer and flat steel washer under the heads of each of the screws. Place the insulating washer over the contact breaker pivot pin and position the contact breaker lever over the pivot pin. Locate the end of the contact breaker spring under the head of

the terminal screw and tighten the nut to lock the spring in position. Adjust the contact breaker setting to give a maximum opening of from .014 in. to .016 in. (.36 mm. to .40 mm.).

**Note.**—*If it becomes necessary to renew the contacts a replacement set comprising fixed and moving contacts must be fitted. During the first few hours' running the initial "bedding-in" of the contact breaker heel will reduce the gap, and after a suitable running-in period (approximately 500 miles) the contact breaker must be examined and the gap reset to the figure quoted above.*

- (f) Place the rotor on the top of the spindle, locating the register correctly, and push it fully home.
- (g) Fit the distributor moulding and secure it by means of the spring clips.