



# **WORKSHOP MANUAL**

***1½ LITRE***

***and***

***2½ LITRE***



# **WORKSHOP MANUAL**

**1½ LITRE**  
**and**  
**2½ LITRE**

## **NOTE**

Amendments to the instructions given in this manual are only made by the issue of revised sheets, or by additional sheets for inclusion at the end of each section.

It is therefore of the utmost importance to refer to the end of each of the sections for the latest instructions before carrying out any work on the vehicle.

*Issued by*

**RILEY MOTORS LIMITED**

*Proprietors: MORRIS MOTORS LIMITED*

**ABINGDON - BERKSHIRE - ENGLAND**

*Sole Exporters*

**NUFFIELD EXPORTS LIMITED**

*Proprietors: MORRIS MOTORS LIMITED*

**COWLEY - OXFORD - ENGLAND**



THIS MANUAL HAS BEEN REPRODUCED BY KIND PERMISSION OF

AUSTIN-MORRIS DIVISION  
BRITISH LEYLAND MOTOR CORPORATION  
COWLEY. OXFORD

THIS EDITION DESIGNED BY J. A. BYRON FOR THE RILEY RM CLUB  
AND THE EXCLUSIVE USE OF ITS MEMBERS.

PRINTED IN ENGLAND 1979



C

# CONTENTS

	<i>Section</i>
General Data	
General Information	
Maintenance Attention (Free and Periodical)	
Frost Precautions	
General Data (Series RME and RMF)	
Engine (2½ litre) ... ..	A
Engine (1½ litre) ... ..	AA
Engine (2½ litre, Series RMF) ... ..	AAA
Fuel System (2½ litre) ... ..	B
Fuel System (1½ litre) ... ..	BB
Ignition System (1½ and 2½ litre) ... ..	C
Cooling System (1½ and 2½ litre) ... ..	D
Clutch (1½ and 2½ litre) ... ..	E
Gearbox (1½ and 2½ litre) ... ..	F
Intermediate Driving Shaft (1½ and 2½ litre) ... ..	G
Intermediate Driving Shaft and Propeller Shaft (Series RME and RMF) ... ..	GG
Rear Axle (1½ and 2½ litre) ... ..	H
Rear Axle (Series RME and RMF) ... ..	HH
Rear Road Springs (1½ and 2½ litre) ... ..	J
Front Suspension (1½ and 2½ litre) ... ..	K
Hydraulic Dampers (1½ and 2½ litre) ... ..	L
Braking System (1½ and 2½ litre) ... ..	M
Braking System (Series RME and RMF) ... ..	MM
Electrical Equipment (1½ and 2½ litre) ... ..	N
Wheels and Tyres (1½ and 2½ litre) ... ..	O
Lubrication (1½ and 2½ litre) ... ..	P
Special Tools (1½ and 2½ litre) ... ..	Q
Body (1½ and 2½ litre) ... ..	R

# GENERAL DATA

## (1½ LITRE)

<b>ENGINE</b>				
Number of cylinders	...	...	...	Four.
Capacity	...	...	...	1496 c.c. (91.28 cu. in.).
B.H.P.	...	...	...	54 at 4,500 r.p.m.
Bore	...	...	...	69 mm. (2.7165 in.).
Stroke	...	...	...	100 mm. (3.937 in.).
Compression ratio	...	...	...	6.8 to 1.
System of cooling	...	...	...	Thermo-siphon, fan and pump.
Radiator hose, top (outlet)	...	...	...	Pre-formed to fit thermostat.
Radiator hose—pump to head	...	...	...	2 in. long × 1½ in. outside diameter (5.08 cm. × 3.81 cm.). Inside diameter to fit tight over 1¼ in. (3.175 cm.) diameter tube.
Radiator hose—radiator to pump	...	...	...	2½ in. long × 1⅝ in. outside diameter (6.67 cm. × 4.13 cm.). Inside diameter to be a push fit on 1¼ in. (3.175 cm.) diameter tube.
First oversize bore	...	...	...	+ .020 in. (+.5 mm.). Bore 2.7365 in. (69.5 mm.).
Second oversize bore (max.)	...	...	...	+ .040 in. (+1.0 mm.). Bore 2.7565 in. (70 mm.).
Firing order	...	...	...	1, 2, 4, 3.
Piston clearance, top	...	...	...	.0024 in. to .0034 in. (.061 mm. to .086 mm.).
Piston clearance, bottom	...	...	...	.0012 in. to .003 in. (.03 mm. to .076 mm.).
Ring gap	...	...	...	.006 in. to .010 in. (.152 mm. to .254 mm.).
Number of compression rings	...	...	...	Three.
Width of compression rings	...	...	...	.079 in. (2 mm.).
Number of oil control rings	...	...	...	One.
Width of oil control rings	...	...	...	⅝ in. (3.969 mm.).
Oil pressure release valve	...	...	...	50 lb./sq. in. (3.5 kg./cm. <sup>2</sup> ).
Gudgeon pin type	...	...	...	Floating.
Gudgeon pin diameter	...	...	...	.750 in. $\left\{ \begin{array}{l} +.000 \text{ in.} \\ -.0003 \text{ in.} \end{array} \right.$ 19 mm. $\left\{ \begin{array}{l} +.000 \text{ mm.} \\ -.006 \text{ mm.} \end{array} \right.$
Fit in piston	...	...	...	Hard push fit at 70° C.
Fit in connecting rod	...	...	...	Push.
Gudgeon pin—oversize	...	...	...	+ .002 in. (.051 mm.).
Crankpin diameter—standard	...	...	...	1.875 in. (4.763 cm.).
Crankpin, minimum diameter for regrind	...	...	...	— .040 in. (—1.0 mm.).
Connecting rod centres...	...	...	...	8 in. (20.32 cm.).
Connecting rod—type of bearing	...	...	...	White metal direct.
Connecting rod—side clearance	...	...	...	.002 in. to .004 in. (.05 mm. to .10 mm.).
Connecting rod—diametrical clearance	...	...	...	.0015 in. (.038 mm.).
Number of crankshaft bearings	...	...	...	Three.
Type of main bearings	...	...	...	Thick white-metal lined.
Standard main journal diameter	...	...	...	Front and rear 1.75 in. (4.445 cm.). Centre 2.75 in. (6.985 cm.).
<b>Main Journals</b>				
First regrind diameter	...	...	...	— .020 in. (—.508 mm.).
Second regrind diameter (minimum)	...	...	...	— .040 in. (—1.1 mm.).
Main bearings—end clearance	...	...	...	.004 in. to .006 in. (.1 mm. to .15 mm.).
Main bearings—diametrical clearance	...	...	...	.0025 in. (.060 mm.) centre. .0015 in. (.040 mm.) front and rear.
Crankshaft end thrust	...	...	...	On rear bearing.
Number of camshaft bearings	...	...	...	Three.
Type of camshaft bearings	...	...	...	Bronze at front and rear. Centre bearing is machined in block.



GENERAL DATA—*continued*

## FRONT AXLE AND STEERING

Camber	...	...	...	...	1°.
Castor	...	...	...	...	3°.
Toe-in	...	...	...	...	Nil.
King-pin inclination	...	...	...	...	11°.
Track	...	...	...	...	4 ft. 4¼ in. (1.327 m.).
Turning circle	...	...	...	...	30 ft. (9.144 m.).
Wheelbase	...	...	...	...	9 ft. 4½ in. (2.858 m.).
Tyre size	...	...	...	...	5.75 × 16.
Tyre pressure	...	...	...	...	Front, 22 lb./sq. in. (1.6 kg./cm. <sup>2</sup> ). Rear, 24 lb./sq. in. (1.7 kg./cm. <sup>2</sup> ).

## REAR AXLE (Early Models)

Type	...	...	...	...	Semi-floating.
Drive	...	...	...	...	Spiral bevel.
Ratio	...	...	...	...	4.89 to 1.
Adjustment	...	...	...	...	By distance-pieces on pinion. Crown wheel set by screwed sleeves.

## REAR AXLE (RME Models)

Type	...	...	...	...	Semi-floating.
Drive	...	...	...	...	Hypoid.
Ratio	...	...	...	...	8/41 = 5.125 to 1.
Adjustment	...	...	...	...	By distance-pieces on pinion and differential.

## BRAKES (Early Models)

Type	...	...	...	...	Girling hydro-mechanical.
Brake lining size	...	...	...	...	Front, 8⅞ in. × 1¼ in. × ⅜ in. (21.27 cm. × 4.45 cm. × .48 cm.). Rear, 9⅞ in. × 1½ in. × ⅜ in. (23.18 cm. × 3.81 cm. × .48 cm.).
Brake lining make	...	...	...	...	Don BS5.
Brake lining—number of rivets	...	...	...	...	12.
Brake rivet size	...	...	...	...	⅜ in. diameter × ⅜ in. long (.48 cm. × .95 cm.).

## BRAKES (RME Models)

Type	...	...	...	...	Girling hydraulic.
Brake lining size	...	...	...	...	Front, 9.6 in. × 1⅜ in. × ⅜ in. (24.38 cm. × 4.45 cm. × .48 cm.). Rear (Leading Shoe), 9.6 in. × 1¼ in. × ⅜ in. (24.38 cm. × 4.45 cm. × .48 cm.). Rear (Trailing Shoe), 8.7 in. × 1⅜ in. × ⅜ in. (22.10 cm. × 4.45 cm. × .48 cm.).
Brake lining make	...	...	...	...	Mintex M.20.
Brake lining—number of rivets	...	...	...	...	10.
Brake rivet size	...	...	...	...	.171 in. to .175 in. diameter × ⅜ in. long (.43 cm. to .44 cm. × .95 cm.) overall.

## DAMPERS

Front	...	...	...	...	Luvax DA/6/5—No. 9046/356. Up to Chassis No. 40S/18781, when Girling CDR5 were fitted.
Rear	...	...	...	...	Luvax PR6/56Y—Right-hand. PR6/57X—Left-hand. Ceased at Chassis No. 39S/16222. Luvax PV6/56 SA133/70—Right-hand. PV6/57 SA133/69 Left-hand up to Chassis No. 40S/18780. From Chassis No. 40S/18781 Girling type DAS9 (not handed) were fitted.

(1½ LITRE)

## GENERAL DATA—continued

### SPRINGS (Early Type)

Front	...	...	...	...	Torsion bars.
Rear	...	...	...	...	Semi-elliptic.
Working load—torsion bar	...	...	...	...	708 lb. (321 kg.).
Working load—rear	...	...	...	...	750 lb. (340 kg.).
Spring, length	...	...	...	...	45½ in. ± ⅛ in. (115.57 cm. ± 1.6 cm.) eye to eye.
Spring, width	...	...	...	...	2 in. (5.08 cm.) × ⅜ in. (4.76 mm.).
Spring, number of leaves	...	...	...	...	10.
Spring, free camber	...	...	...	...	4 in. (10.16 cm.) from flat spring.
Spring, working camber	...	...	...	...	1⅞ in. (4.76 cm.) negative from flat spring.

### SPRINGS (RME Models)

Front	...	...	...	...	Torsion bars.
Rear	...	...	...	...	Semi-elliptic.
Working load—torsion bar	...	...	...	...	708 lb. (321 kg.).
Working load—rear	...	...	...	...	800 lb. (362.9 kg.).
Spring, length	...	...	...	...	45½ in. ± ⅛ in. (115.57 cm. ± 1.6 cm.) eye to eye.
Spring, width	...	...	...	...	2 in. (5.08 cm.) × ⅜ in. (4.76 mm.).
Spring, number of leaves	...	...	...	...	11.
Spring, free camber	...	...	...	...	4 in. (10.16 cm.) from flat spring.
Spring, working camber	...	...	...	...	1⅝ in. (4.45 cm.) negative from flat spring.

### ELECTRICAL

Distributor rotation	...	...	...	...	Clockwise (viewed from above).
Manual advance	...	...	...	...	10° to 12° (on crankshaft).
Automatic advance	...	...	...	...	Centrifugal weights.
Contact breaker gap (early type)	...	...	...	...	.010 in.—.012 in. (.25 mm. to .30 mm.).
Contact breaker gap (later type with high-lift cams)	...	...	...	...	.014 in.—.016 in. (.36 mm. to .41 mm.).
Spark plug	...	...	...	...	Champion L.10S.
Spark plug gap	...	...	...	...	.025 in. (.64 mm.).
Ignition timing	...	...	...	...	8° before T.D.C. full advance.
Charging system	...	...	...	...	Compensated voltage control.
Battery	...	...	...	...	Lucas 12-volt, type GTW9A, 51 amp./hrs. at 10 hrs.
Battery earth	...	...	...	...	Positive.

### CAPACITIES

Sump	...	...	...	...	10 pints (5.7 litres)
Gearbox	...	...	...	...	2 pints (1.13 litres).
Rear axle	...	...	...	...	RME 2½ pints (1.42 litres), early models 2¾ pints.
Cooling system	...	...	...	...	13 pints (7.4 litres).
Fuel	...	...	...	...	12½ gallons (56.8 litres).

### GENERAL DIMENSIONS

Overall length	...	...	...	...	14 ft. 11 in. (4.55 m.).
Overall width	...	...	...	...	5 ft. 3½ in. (1.613 m.).
Overall height	...	...	...	...	5 ft. ½ in. (1.54 m.).
Ground clearance	...	...	...	...	7½ in. (19 cm.).
Weight	...	...	...	...	24¼ cwt. (1232 kg.).

### TORQUE WRENCH READINGS

Main bearing cap nuts : front and centre	...	...	...	...	250 in./lbs. (2.87 m./kg.).
rear	...	...	...	...	780 in./lbs. (8.97 m./kg.).
Connecting rod big-end nuts	...	...	...	...	420 in./lbs. (4.83 m./kg.).
Cylinder head stop nuts	...	...	...	...	540 in./lbs. (6.21 m./kg.).
Flywheel bolts	...	...	...	...	850 in./lbs. (9.77 m./kg.).

# GENERAL DATA

(2½ LITRE)

## ENGINE

Number of cylinders	... ..	Four.
Capacity	... ..	2443 c.c. (149 cu. in.).
B.H.P.	... ..	100 at 4,400 r.p.m.
Bore	... ..	80.5 mm. (3.169 in.).
Stroke	... ..	120 mm. (4.724 in.).
Compression ratio	... ..	RMF 6.6 to 1. Early models 6.8 to 1.
System of cooling	... ..	Pump, thermo-siphon and fan.
Radiator hose top (outlet)	... ..	Pre-formed to fit thermostat.
Radiator hose diameter—radiator to pump	... ..	1¼ in. (31.7 mm.).
Radiator hose diameter—pump to head	... ..	1¼ in. (31.7 mm.).
Radiator hose top (outlet)	... ..	1⅝ in. (34.9 mm.), internal dia. × 6⅝ in. (16.8 cm.) long. RMF models.
Radiator hose (RMF)—radiator to head	... ..	1¼ in. (31.7 mm.), internal dia. × 2⅝ in. (66.7 mm.) long.
First oversize bore	... ..	+ .020 in. (.5 mm.). Bore size 3.189 in. (81 mm.).
Second oversize bore (max.)	... ..	+ .040 in. (1.0 mm.). Bore size 3.209 in. (81.5 mm.).
Firing order	... ..	1, 2, 4, 3.
Piston clearance, top	... ..	.002 in. to .0033 in. (.05 mm. to .084 mm.).
Piston clearance, bottom	... ..	.0018 in. to .0026 in. (.046 mm. to .066 mm.).
Ring gap	... ..	.008 in.—.012 in. (.2 mm.—.3 mm.).
Number of compression rings	... ..	Two.
Width of compression rings	... ..	.0927 in. to .0937 in. (2.35 mm. to 2.38 mm.).
Number of oil control rings	... ..	Two.
Width of oil control rings	... ..	.1565 in. to .1575 in. (3.88 mm. to 3.90 mm.).
Oil pressure release valve operates	... ..	60 lb./sq. in. (4.2 kg./cm. <sup>2</sup> ). RMF 50 lb./sq. in. (3.5 kg./cm. <sup>2</sup> ).
Gudgeon pin type	... ..	Floating.
Gudgeon pin diameter	... ..	.866 in. (22 mm.).
Fit in piston	... ..	Hard push at 70° C.
Fit in connecting rod	... ..	Push.
Gudgeon pin oversizes	... ..	+ .002 in. (.051 mm.).
Crankpin diameter (standard)	... ..	2.362 in. (60 mm.).
Crankpin minimum diameter for regrind	... ..	2.322 in. (58.98 mm.) (— .040 in. (1.0 mm.)).
Connecting rod—length between centres	... ..	8.625 in. (21.91 cm.).
Connecting rod—type of bearing (engines prior to No. RMB2/945)	... ..	White-metal cast direct on rod.
Connecting rod—type of bearing (engines from No. RMB2/945 onwards)	... ..	Top half : lead-bronze. Lower half : steel-backed, white-metal lined.
Connecting rod—side clearance	... ..	.002 in.—.008 in. (.05 mm.—.2 mm.).
Connecting rod—diametrical clearance	... ..	.0015 in. (.038 mm.).
Number of crankshaft bearings	... ..	Three.
Type of main bearings	... ..	Thick, white-metal lined, bronze shells.
Standard main journal diameter	... ..	2.559 in. (65 mm.).
Main journals		
First regrind diameter	... ..	.020 in. (.5 mm.).
Second regrind diameter (minimum)	... ..	.040 in. (1.1 mm.).
Main bearings—length	... ..	1.938 in. (49.25 mm.) front and centre. 2.7559 (70 mm.) rear.
Main bearings—end clearance	... ..	Zero to .004 in. (0 mm. to .10 mm.).
Main bearings—diametrical clearance	... ..	.001 in. to .003 in. (.025 mm. to .075 mm.).
Crankshaft—end thrust on	... ..	Rear bearing (flanged both sides).
Number of camshaft bearings	... ..	Three.

(2½ LITRE)

GENERAL DATA—continued

Type of camshaft bearings	...	...	...	...	Bronze bushes.
Camshaft—bearing clearance	...	...	...	...	.0015 in. to .004 in. (.0375 mm. to .10 mm.).
Camshaft—end thrust on	...	...	...	...	Front face of front bearings.
Camshaft drive	...	...	...	...	Duplex roller chain.
Valve timing markings	...	...	...	...	Crankshaft keyway vertical and marks on chain wheels (bright links on chain on RMF).
Exhaust valve throat diameter	...	...	...	...	1.476 in. (37.49 mm.).
Exhaust valve diameter	...	...	...	...	Head 1.604 in. (40.7 mm.). Stem $\frac{5}{16}$ in. (7.94 mm.).
Inlet valve throat diameter	...	...	...	...	1.702 in. (43.15 mm.).
Inlet valve diameter	...	...	...	...	Head, early models 1.856 (47.14 mm.) ; RMF 1.830 in. (46.48 mm.). Stem $\frac{5}{16}$ in. (7.94 mm.).
Valve seat angle	...	...	...	...	45°.
Tappet type	...	...	...	...	Hollow.
Valve lift inlet	...	...	...	...	.390 in. (9.9 mm.).
Valve lift exhaust	...	...	...	...	.390 in. (9.9 mm.).
Inlet valve opens	...	...	...	...	12° before T.D.C.
Inlet valve closes	...	...	...	...	
Exhaust valve opens	...	...	...	...	55° before B.D.C.
Exhaust valve closes	...	...	...	...	20° after T.D.C.
Valve spring—shut	...	...	...	...	68.6 lb. (31.12 kg.).
Valve spring—open	...	...	...	...	111 lb. (50.35 kg.).
Inlet valve opens—piston traverse	...	...	...	RMF	.0657 in. (1.67 mm.) before T.D.C.
Inlet valve working clearance	...	...	...	...	.011 in. (.28 mm.). Hot engine.
Exhaust valve working clearance	...	...	...	...	.011 in. (.28 mm.). Hot engine.
Valve guides	...	...	...	...	Renewable.

Early Models	17° before T.D.C.
	43° after B.D.C.
	45° before B.D.C.
	20° after T.D.C.
	64.5 lb. (29.26 kg.).
	99.5 lb. (45.13 kg.).
	.13084 in. (3.3 mm.) before T.D.C.
	.003 in. (.076 mm.). Hot engine.
.004 in. (.1 mm.). Hot engine.	

FUEL SYSTEM

Fuel tank level	...	...	...	...	Electric gauge on panel.
Fuel delivery	...	...	...	...	S.U. electric pump, Type L.
Carburettors	...	...	...	...	S.U. horizontal, H4 (two).
Carburettor needles	...	...	...	...	Normal—E.E.; Weak—E.M.; No rich setting is recommended.

CLUTCH

Type	...	...	...	...	Borg and Beck, 10/73C., 10 in. (25.4 cm.) diameter.
Facing	...	...	...	...	Ferodo RYZ.

GEARBOX

Synchromesh	...	...	...	...	Second, third, top.
Ratios :					
Overall	...	...	...	RMF	First and reverse 14.949 to 1. Second 8.835 to 1. Third 5.814 to 1. Top 4.1 to 1.
Gearbox	...	...	...	...	First and reverse 3.646 to 1. Second 2.155 to 1. Third 1.418 to 1. Top 1 to 1.

Early Models	15.0 to 1.
	8.86 to 1.
	5.83 to 1.
	4.11 to 1.

## GENERAL DATA—continued

## FRONT AXLE AND STEERING

Camber	...	...	...	...	...	1°.
Castor angle	...	...	...	...	...	3°.
Toe-in	...	...	...	...	...	Nil.
Swivel pin inclination	...	...	...	...	...	11°.
Tyre size	...	...	...	...	...	6.00—16.
Tyre pressures (all wheels)	...	...	...	...	...	24 lb./sq. in. (1.7 kg./cm. <sup>2</sup> ).
Wheel size	...	...	...	...	...	4.50×16.

## REAR AXLE (Early Type)

Type of axle	...	...	...	...	...	Semi-floating.
Type of drive	...	...	...	...	...	Spiral bevel.
Ratio	...	...	...	...	...	37/9.
Adjustment	...	...	...	...	...	By distance-pieces for pinion. Crown wheel set by screwed bearing housings.

## REAR AXLE (RMF)

Type of axle	...	...	...	...	...	Semi-floating.
Type of drive	...	...	...	...	...	Hypoid.
Ratio	...	...	...	...	...	41/10.
Adjustment	...	...	...	...	...	By distance-pieces for pinion and crown wheel.

## BRAKES (Early Types)

Type	...	...	...	...	...	Girling hydro-mechanical. 12 in. dia. front and rear (30.48 cm.). To Chassis No. 60S/6094. 11 in. dia. front only (27.94 cm.). From Chassis No. 60S/6095 onwards.																
Type of lining	...	...	...	...	...	Mintex M.14.																
Lining size :						<table> <tr> <td>Length</td> <td>10½ in. (26.67 cm.).</td> </tr> <tr> <td>Width</td> <td>1¾ in. (4.21 cm.).</td> </tr> <tr> <td>Thickness</td> <td>⅝ in. (3.97 mm.).</td> </tr> <tr> <td>Number of rivets</td> <td>12.</td> </tr> <tr> <td>Length</td> <td>9⅞ in. (25.1 cm.).</td> </tr> <tr> <td>Width</td> <td>2¼ in. (5.7 cm.).</td> </tr> <tr> <td>Thickness</td> <td>⅜ in. (1.48 cm.).</td> </tr> <tr> <td>Number of rivets</td> <td>12.</td> </tr> </table>	Length	10½ in. (26.67 cm.).	Width	1¾ in. (4.21 cm.).	Thickness	⅝ in. (3.97 mm.).	Number of rivets	12.	Length	9⅞ in. (25.1 cm.).	Width	2¼ in. (5.7 cm.).	Thickness	⅜ in. (1.48 cm.).	Number of rivets	12.
Length	10½ in. (26.67 cm.).																					
Width	1¾ in. (4.21 cm.).																					
Thickness	⅝ in. (3.97 mm.).																					
Number of rivets	12.																					
Length	9⅞ in. (25.1 cm.).																					
Width	2¼ in. (5.7 cm.).																					
Thickness	⅜ in. (1.48 cm.).																					
Number of rivets	12.																					
Up to Chassis No. 60S/6094 Front and rear	...	...	...	...	...																	
From Chassis No. 60S/6095 Front only. Rear as above	...	...	...	...	...																	
Size of rivets	...	...	...	...	...	⅜ in. dia. × ⅝ in. long (1.48 cm. × 1.27 cm.).																

## BRAKES (RMF)

Type	...	...	...	...	...	Girling hydraulic. 11 in. dia. front and rear (27.94 cm.).
Type of lining	...	...	...	...	...	Mintex M.21.
Lining size	...	...	...	...	...	Front : 10.43 in. × 2¼ in. × ⅜ in. (26.49 cm. × 5.7 cm. × 1.48 cm.). Rear (Leading Shoe) : 10.43 in. × 2¼ in. × ⅜ in. (26.49 cm. × 5.7 cm. × 1.48 cm.). Rear (Trailing Shoe) : 9.6 in. × 2¼ in. × ⅜ in. (24.38 cm. × 5.7 cm. × 1.48 cm.). Number of rivets : Twelve.
Size of rivets	...	...	...	...	...	⅜ in. dia. × ⅝ in. long (1.48 cm. × 1.27 cm.) (under head).

(2½ LITRE)

## GENERAL DATA—continued

### SPRINGS

Type—front	...	...	...	...	...	Torsion bar.
Type—rear	...	...	...	...	...	Semi-elliptic.
Working load—front	...	...	...	...	...	850 lb. (389 kg.).
Working load—rear	...	...	...	...	...	800 lb. (362.9 kg.) at 1⅞ in. (47.6 mm.) negative camber.
Length—rear (flat)	...	...	...	...	...	45½ in. (115.57 cm.).
Width—rear	...	...	...	...	...	2 in. (50.8 mm.).
Number of leaves	...	...	...	...	...	11 (early models) ; 12 (RMF open propeller shaft).
Thickness of leaves	...	...	...	...	...	$\frac{3}{16}$ in. (4.76 mm.).
Camber	...	...	...	...	...	Free : 4 in. (10.16 cm.). Working : 1⅜ in. (44.45 mm.) negative (RMF models). : 1⅞ in. (47.6 mm.) negative (early models).

### DAMPERS

Front	...	...	...	...	...	Luvax DA/6/5—No. 9046/356. Changed at Chassis No. 60S/7791 to Girling CDR5.
Rear	...	...	...	...	...	Luvax PR6/68Y—Right-hand ; PR6/69X—Left-hand. Ceased at Chassis No. 59S/4610. From Chassis Nos. 59S/4611 to 60S/7790. Luvax PV6/68, SA133/72—Right-hand. PV6/69, SA133/71—Left-hand. After Chassis No. 60S/7791 rear dampers were Girling DAS9 (not handed).

### ELECTRICAL

Distributor rotation	...	...	...	...	...	Anti-clockwise (RMF) ; clockwise (early models).
Manual advance	...	...	...	...	...	15°.
Automatic advance	...	...	...	...	...	36°.
Contact breaker gap (early type)	...	...	...	...	...	.010 in. to .012 in. (.25 mm. to .30 mm.).
Contact breaker gap (later type with high-lift cams) (See Section C.13)	...	...	...	...	...	.014 in. to .016 in. (.36 mm. to .41 mm.).
Sparking plugs	...	...	...	...	...	Champion NA8, 14 mm. Gap, .025 in. (.64 mm.).
Ignition timing	...	...	...	...	...	4° B.T.D.C.
Charging system	...	...	...	...	...	C.V.C.
Battery	...	...	...	...	...	Lucas 12-volt, type GTW11A. 63 amp./hrs. at 10 hrs.
Battery earth	...	...	...	...	...	Positive.

### CAPACITIES

Sump	...	...	...	...	...	14 pints (7.9 litres).
Gearbox	...	...	...	...	...	2½ pints (1.5 litres).
Rear axle	...	...	...	...	...	RMF 2½ pints (1.42 litres) ; early models 4 pints (2.27 litres).
Cooling system	...	...	...	...	...	21 pints (11.8 litres).
Fuel	...	...	...	...	...	12½ gallons (56 litres).

### GENERAL DIMENSIONS

Length	...	...	15 ft. 6 in. (4.72 m.).
Width	...	...	5 ft. 3½ in. (1.61 m.).
Height	...	...	5 ft. 1 in. (1.55 m.).
Ground clearance	...	...	7 in. (18 cm.).
Wheelbase	...	...	9 ft. 11 in. (3.02 m.).
Track	...	...	4 ft. 4½ in. (1.327 m.).
Turning circle	...	...	36 ft. (11 m.).
Weight	...	...	29¼ cwt. (1486 kg.).

### TORQUE SPANNER READINGS

Main bearing cap nuts	...	...	900 in./lbs. (10.35 m./kg.).
Connecting rod big-end nuts	...	...	450 in./lbs. (5.17 m./kg.).
Cylinder head nuts	...	...	900 in./lbs. (10.35 m./kg.).
Flywheel bolts	...	...	850 in./lbs. (9.77 m./kg.).

## GENERAL INFORMATION

### TO OPEN THE BONNET

The bonnet is in two halves. To open each half it is necessary to pull the knobs, located at the extreme ends of the glove tray, towards the operator to release the locks.

Each bonnet half is held in the vertical position by means of a small stop latch, which is swung round into a slot.

The bonnet is closed by releasing the latch, lowering the bonnet and pressing on the top to engage the bonnet lock.

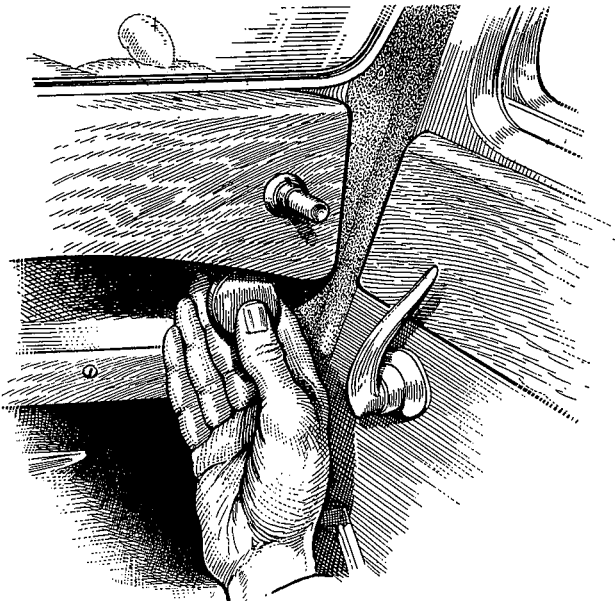

One of the bonnet latch release knobs is shown in this illustration.

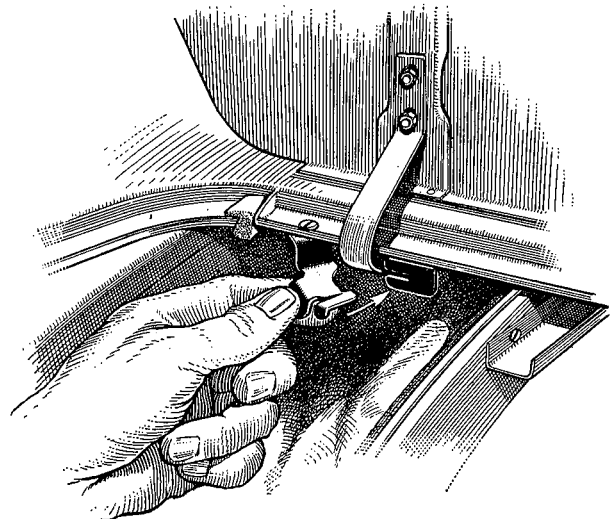

One of the small stop latches which retain the bonnet halves in a vertical position.

### THE CONTROL PANEL

*Mixture Control.* When starting from cold, pull the knob right out to rich and hold it in that position. Immediately the engine has started to run, allow the control to return to its original position as rapidly as possible. Never let the engine run for long periods with this control in the rich position.

*Ignition Switch.* Turn the key in a clockwise direction to switch on. Never leave the ignition switched on when the engine is at rest because this will damage the ignition coil and discharge the battery. The ignition key will also lock the driver's door and boot lid.

*The Starter Switch.* Press the starter switch sharply and release it as soon as the engine fires. Never operate the switch if the motor is still spinning.

*Hand Throttle.* This is a slow-running control for use when the engine is cold. In order to increase the engine speed turn the knob in a counter-clockwise direction. The normal slow running of the engine should be set by the carburettor throttle stop.

*Ignition Control.* To retard the ignition the knob should be pulled out. This hand knob does not give control over the full ignition advance range, only over a portion of it. When the engine is pulling hard, retard the ignition slightly to prevent pinking.

*The Lamp Switch.* This is a two-position switch. Pull out to the first stop to switch on the sidelamps. Twist clockwise and pull again to the second stop to bring the headlamps into operation.

*Foglamp Switch.* This is also a two-position switch. Pull out to the first stop to switch on one lamp. Twist clockwise and pull again to bring both lamps into operation.

(1½ and 2½ LITRE)

## GENERAL INFORMATION—continued

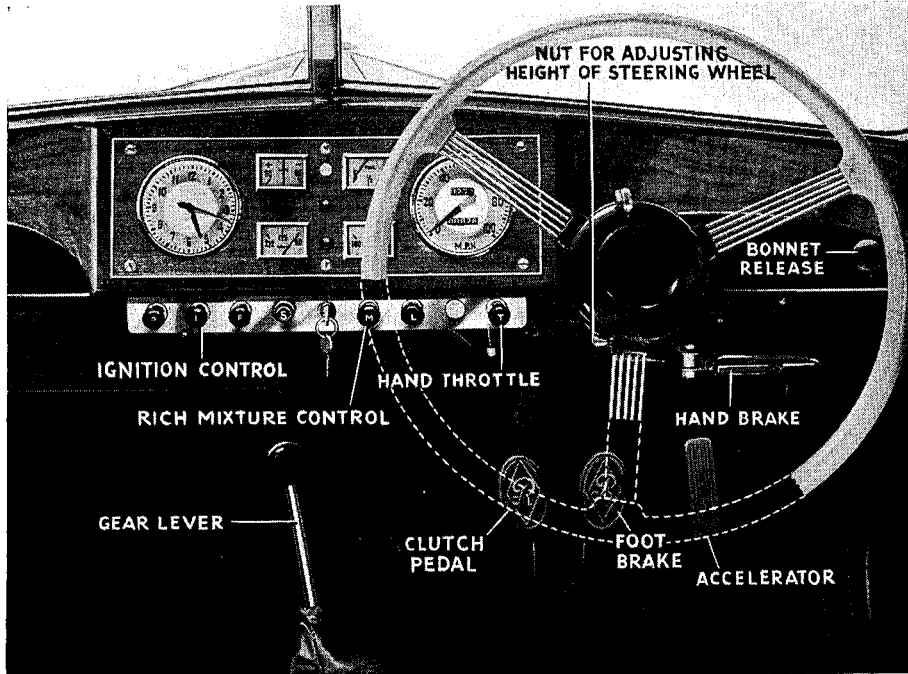

The photograph on the left has been prepared to show the disposition of the engine and driving controls.

*The Headlamp Dipswitch.* The switch controlling the dipping of the headlamps is hand-operated and located on the facia, adjacent to the steering wheel. It is of the repeating type and switches on the full beams and dipped beam with alternate depressions.

*The Panel Light Switch.* The knob must be turned clockwise to bring the lamp into operation. Further rotation decreases the intensity of illumination in order to reduce glare.

*The Windscreen Wiper Control.* The knob must be pulled upwards to bring both wiper blades into automatic action. Depress the knob when the blades are at their extreme travel to stop the operation and park the blades.

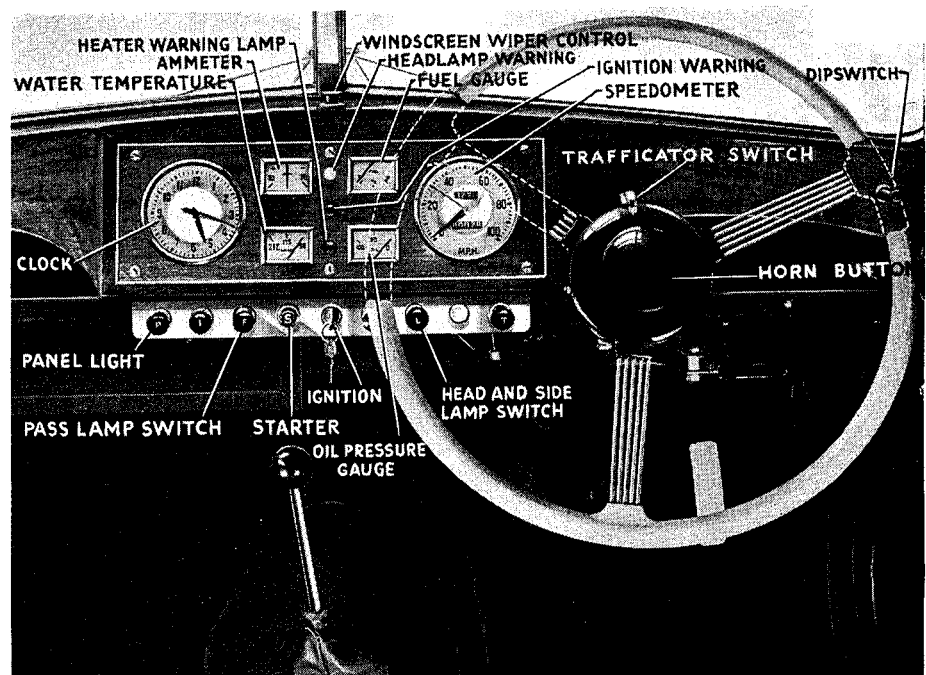

The photograph on the right has been prepared to show the disposition of the instruments and switches.

(1½ and 2½ LITRE)

## GENERAL INFORMATION—continued

### FILLING THE COOLING SYSTEM

The radiator should be filled with water to just below the base of the filler neck, which is located underneath the left-hand side bonnet lid. The cap on the radiator shell is a dummy.

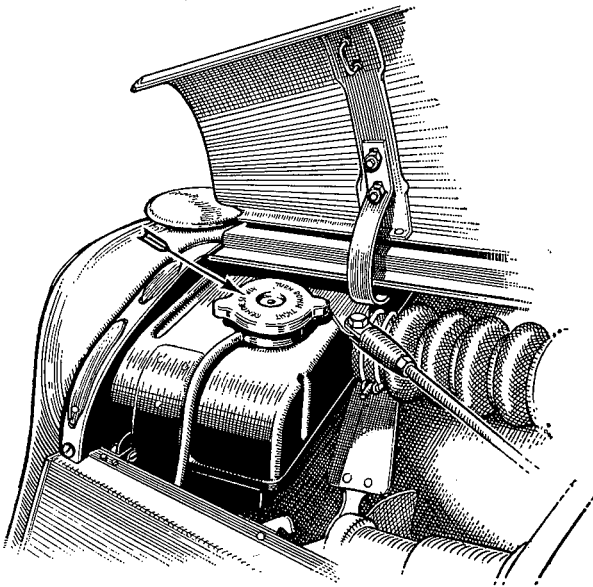

The radiator filler is under the left-hand side of the bonnet.

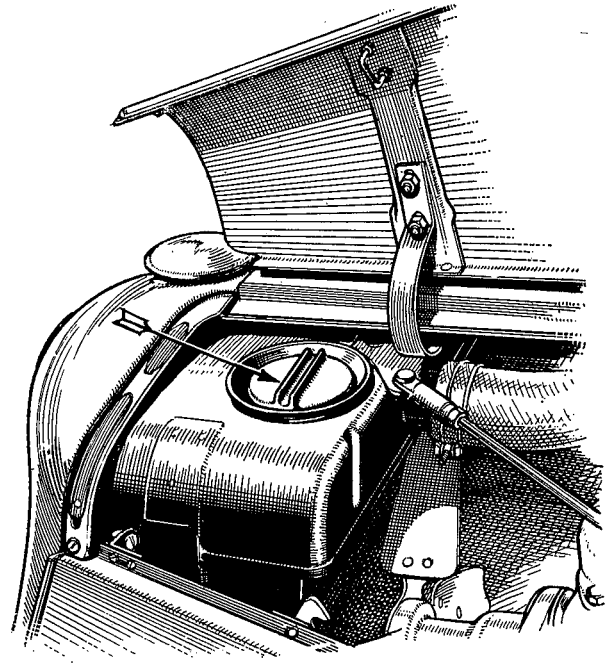

The filler cap fitted to some of the earlier models.

### DRAINING THE COOLING SYSTEM

There are three draining points on the 2½ litre. One tap is at the base of the radiator on the right-hand side, another is on the left-hand side of the cylinder block and just above the starter motor. The third tap is on the forward end of the inlet manifold. On the 1½ litre there are two points, one at the base of the radiator and the other just forward of the fuel pump on the side of the cylinder block. See Section D for the positions of the drain taps.

### THE TOOL KIT

All the tools are stored in the tool compartment under the bonnet. The starting handle is located in the boot.

### WARMING UP THE ENGINE

As soon as the engine has started, let the mixture control spring back. If the engine falters, pull the control out approximately half way. Do not race the engine but let it run at a fast tick-over. This speed should be approximately 1,000 r.p.m., corresponding to 20 m.p.h. (32 k.p.h.) in top gear, until the engine has attained its correct working temperature of approximately 72° C. (162° F.).

Blanking off the radiator will assist in warming the engine in cold weather, but never run the car with the radiator completely masked.

Less damage is done to the engine by taking the car straight onto the road than by letting it idle in the garage, provided it is driven reasonably and the engine is not allowed to race. The quicker the engine is allowed to warm up the better.

(1½ and 2½ LITRE)

## GENERAL INFORMATION—continued

### CHASSIS AND ENGINE NUMBERS

A plate on the left-hand side of the crankcase, just forward of the exhaust manifold carries the engine number and type. The chassis number is stamped on the top of the frame on the left-hand side, near the starter motor. There is a plate on the left-hand side of the engine bulkhead bearing the chassis number.

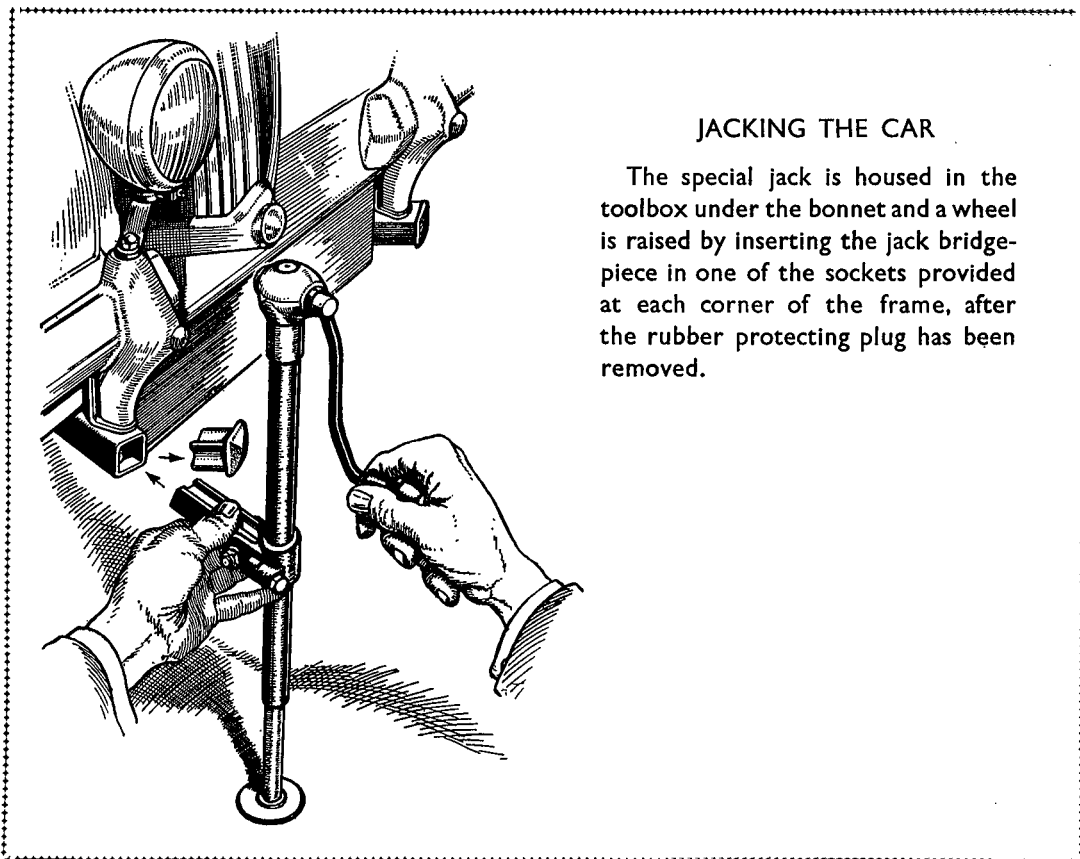
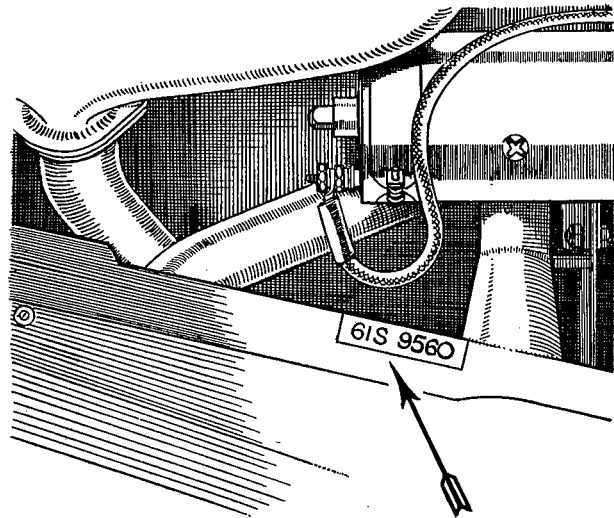

### JACKING THE CAR

The special jack is housed in the toolbox under the bonnet and a wheel is raised by inserting the jack bridge-piece in one of the sockets provided at each corner of the frame, after the rubber protecting plug has been removed.

GENERAL INFORMATION—*continued*

## IDENTIFICATION OF "UNIFIED" SCREW THREADS

The general standardisation of "Unified" screw threads makes it necessary to identify all nuts, bolts, and set screws with these threads in order to ensure their correct use with correspondingly threaded components and the fitting of correct replacements.

Identification has been standardised and is effected in the following manner :—

**Nuts.** By a circular groove turned on the end face of the nut or by connected circles stamped on one flat of the hexagon.

**Bolts and Set Screws.** By a circular depression turned on the head or by connected circles stamped on one flat of the hexagon.

**Wheel Stud Nuts.** By a notch cut in all the corners of the hexagon.

These identification marks are clearly shown in the illustration below and it is obviously of the utmost importance that any nuts, bolts, or set screws so marked are used only in conjunction with their associated components having "Unified" threads and that only replacement

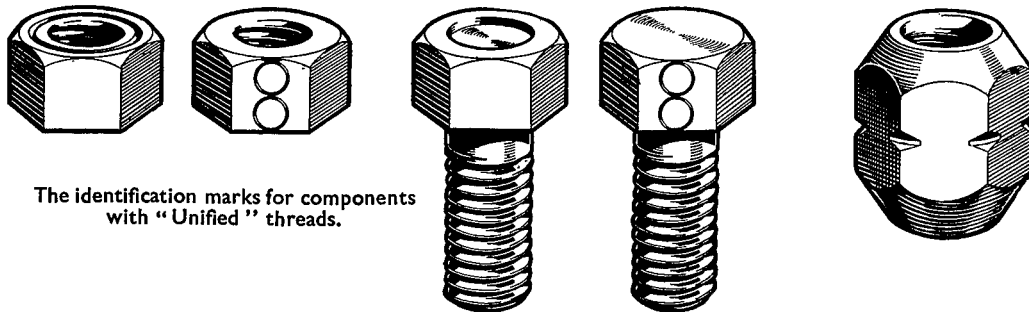

The identification marks for components with "Unified" threads.

parts with "Unified" threads are used, as these are *not* interchangeable with Whitworth, B.S.F. or Metric threads.

The "Unified" thread is, however, interchangeable with the American National Fine (A.N.F.) thread for all practical purposes.

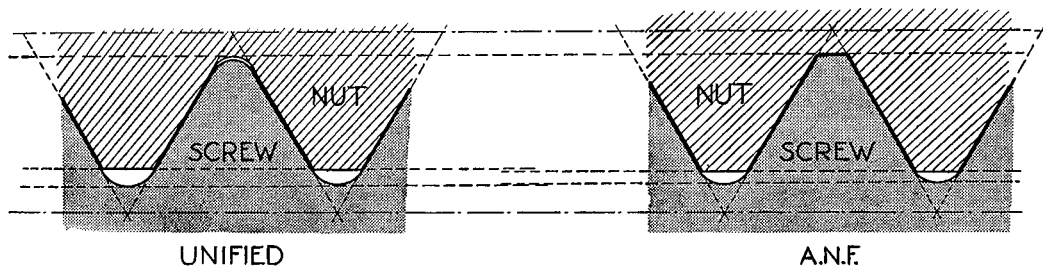

This illustration of the "Unified" thread and A.N.F. thread to the same scale indicates their close relationship.

As an interim measure, prior to the standardisation of the "Unified" thread, certain of the Hypoid axles fitted to Nuffield vehicles have been manufactured with A.N.F. threaded components, and such axles are identifiable from the fact that they are fitted with wheel stud nuts having the notch-type identification on the corners of the hexagon.

Care must be taken, in the case of these axles, to use the correct nuts, bolts and set screws when reassembling or when fitting new components. With the exception of the wheel bolts (which are notched) there is no identification mark on A.N.F. threaded bolts, nuts, and set screws by which they can be identified readily.

(1½ and 2½ LITRE)

## GENERAL INFORMATION—continued

Components and assemblies which have "Unified" threads or A.N.F. threads will be identifiable by the new part numbers which have been allocated to them.

Certain service parts supplied with B.S.F. threads will bear no part numbers.

Thus—Assemblies with the old part numbers or without part numbers have B.S.F. threads.

Assemblies with the new part numbers have "Unified" threads or A.N.F. threads.

*Spanners.* It is to be noted that all A.N.F. and "Unified" threaded nuts and hexagon-headed bolts are made to the standard American hexagon sizes and that spanners of the appropriate size must be used when tightening or loosening them.

### KEY TO SPANNER SIZES Nominal widths between jaws

Nuffield Standards	Diameter of Screw Thread (inches)									
	¼"	⅝"	¾"	7/16"	½"	9/16"	⅝"	¾"	7/8"	1"
For B.S.F. screws and nuts	.448	.529	.604	.705	.825	.925	1.016	1.207	1.309	1.489
For A.N.F. screws and nuts	.440	.504	.566	.629	.755	.880	.944	1.132	1.320	1.508
For "Unified" screws	.440	.504	.566	<b>.630</b>	.755	<b>.817</b>	.943	1.132	1.321	1.509
For "Unified" nuts (normal)	.440	.504	.566	<b>.692</b>	.755	<b>.880</b>	.943	1.132	1.321	1.509
For "Unified" nuts (heavy)	—	—	—	—	—	—	<b>1.069</b>	<b>1.258</b>	<b>1.446</b>	—

**NOTE** :—In the case of some "Unified" threaded components the size of the hexagon for the nut is different from that of the bolt. Where this occurs the spanner size is shown in heavy type in the above table.

### IMPORTANT

The nut and bolt sizes given in this manual refer only to the size of spanner required to deal with them. Unless otherwise stated, the standard Whitworth spanner size is given to deal with the B.S.F. threads originally used, in accordance with the usual practice, i.e. a ¼ in. spanner is required to undo a bolt which has a ⅝ in. B.S.F. thread.

It is to be noted, however, that later models employ A.N.F. or "Unified" threads on certain components with a different size of hexagon, necessitating the use of spanners of a different size. A key to the relative spanner sizes and to the identification of "Unified" threaded components is to be found above.



(1½ and 2½ LITRE)

## MAINTENANCE ATTENTION

### FIRST 500 MILES (800 KM.) FREE SERVICE ATTENTION

- Drain oil from engine, gearbox and rear axle, and refill.
- Oil and grease all points of the car.
- Tighten cylinder head and manifold nuts to recommended pressures.
- Check tightness of valve rocker-shaft brackets to recommended pressures.
- Check tappet clearances and reset if necessary.
- Tighten fan belt if necessary.
- Check all water connections and tighten clips if necessary.
- Examine and clean carburettor and reset slow-running adjustment if necessary.
- Examine and adjust, if necessary, sparking plug and distributor points.
- Check working of automatic ignition controls and, if necessary, reset ignition timing.
- Check front wheel alignment and steering connections. Adjust if necessary.
- Check tightness of universal joint nuts, wheel nuts, spring clips and wing (fender) bolts.
- Check clutch pedal for free movement and adjust if necessary.
- Check fluid level in master cylinder and top up if necessary.
- Check braking system functionally and bleed lines if necessary.
- Check electrical system functionally.
- Examine battery and top up to proper level with distilled water or diluted acid as may be required. Clean and tighten terminals.
- Inspect shock absorbers for leaks. Examine oil levels and top up if necessary (piston type only).
- Test tyres for correct pressures.
- Check doors for ease in opening and closing. If necessary lightly smear with a suitable lubricating agent all dovetails and striking plates.
- Where the Jackall jacking system is in use, check union nuts to recommended pressures and, if necessary, top up the fluid reservoir.

All materials chargeable to the customer.

### PERIODICAL ATTENTION

**Every 250 miles (400 km.) :** Inspect oil level in engine. Refill if necessary to Ref. A (page P.2).

**Every 500 miles (800 km.) :** See that wheel nuts are tight.

See that the radiator is full of water. The water level should be ½ in. (12 mm.) below the filler neck and never allowed to sink so low that the cylinder outlet pipe opening is not fully covered.

Test tyre pressures. (See Section O.1.)

**Every 1,000 miles (1600 km.) :** Inspect oil level in gearbox and rear axle. Refill if necessary.

Attach grease gun filled with grease to Ref. D (page P.2) to the following grease nipple fittings (10 in all) and give the pump two or three strokes :—

4 on swivel pins. 4 on track-rods. 1 on water pump shaft to Ref. C (page P.2), 1 on clutch compensating shaft.

Examine level in Girling brake supply tank and replenish with Girling fluid if necessary. The tank should never be allowed to be less than half-full of fluid nor closer than ½ in. (12 mm.) to the bottom of the filler opening.

Top up battery with distilled water.

Add engine oil to Ref. F (page P.2) to carburettor piston dashpot (later 1½ litre models only).

Apply grease gun filled with grease to Ref. D (page P.2) to transmission sliding joint and universal joint nipples.

Use the oilcan sparingly on the carburettor controls, bonnet locks and operating mechanism, seat adjusters, and brake-rod fork ends.

(1½ and 2½ LITRE)

## MAINTENANCE ATTENTION—*continued*

**Every 3,000 miles (5000 km.) :** Drain engine and refill with fresh oil. (Page P.2.)

Withdraw rotating arm from distributor and add a few drops of engine oil to Ref. F (page P.2) in the aperture. Also lubricate the automatic advance mechanism with engine oil through the hole provided in the contact breaker base plate.

Add a smear of grease to Ref. D (page P.2) to the distributor cam contact breaker pivot and to the face of the cam.

Check contact breaker gap.

Clean and re-oil air cleaner (overseas conditions).

Clean petrol pump contact points (2½ litre).

Check dynamo belt tension.

Lubricate rear spring leaves with oil to Ref. F (page P.2).

Remove dynamo lubricator, half-fill with grease to Ref. C (page P.2) and replace.

Examine the gaps of the sparking plug points and make sure that they are not too wide ; they should be .025 in. (.64 mm.).

**Every 6,000 miles (10000 km.) :** Remove the filters from the carburetters and petrol pump, clean and replace. (See Section B.)

Fit new oil filter element (2½ litre).

Clean and re-oil air cleaner (home conditions).

Drain gearbox and rear axle. Refill with fresh oil to Ref. B (pages P.2 or P.3 according to the type of axle).

Oil Trafficators.

Remove wheel hub covers, substitute a grease nipple for each screwed plug, and give one stroke of grease gun to each nipple. Use grease to Ref. C (page P.2). No lubrication attention is required to the rear wheels on later models and the screwed plug is discontinued. The front wheel hub caps on later models should be removed and repacked with grease to Ref. C.

Give one stroke of grease gun (use grease to Ref. C on page P.2) to grease nipple on hand brake cable.

Check valve clearance.

Tighten door-hinge fixing screws.

Tighten spring seat bolts.

Apply grease gun to door hinges.

**Every 12,000 miles (20000 km.) :** Remove sump, clean and replace. Refill sump with fresh oil.

Change the oil filter complete (1½ litre).

Remove rear dampers (piston-type), clean and replenish if necessary. (Telescopic dampers on the front and those fitted to the rear of later models should be removed, checked and replaced if faulty.)

Replace sparking plugs with new ones.

Adjust dynamo and starter brushes.

Adjust clutch pedal clearances. (See Section E.1.)

**Every 30,000 miles (50000 km.) :** Re-pack steering gearbox with grease either by dismantling the unit or substituting a grease nipple for the steering stop, and using a grease gun filled with grease to Ref. D (page P.2).

Grease to Ref. D (page P.2) should also be inserted through the damper pad cover at the end of the steering pinion.

(1½ and 2½ LITRE)

## FROST PRECAUTIONS

If the car is not stored in a warmed building, steps must be taken to prevent the cooling water from freezing in frosty weather. Water, upon freezing, expands, with the result that there is considerable risk of bursting either the radiator, the cylinder block or the heater unit by the pressure generated.

As there is no provision for draining the heater unit, it is essential to use anti-freeze in the cooling system in severe weather on cars fitted with a heater.

We recommend the use of Smiths "Bluecol", Shell "Snowflake" or Filtrate "Nevafreze" non-corrosive anti-freeze in order to protect the cooling system and reduce corrosion to a minimum.

The recommended quantities of anti-freeze for different degrees of frost resistance are :—

Down to 7° F. (—14° C.) (15 per cent. solution)		Down to 0° F. (—18° C.) (20 per cent. solution)	
1½ litre.	Quantity 2 pints (1.14 litres)	1½ litre.	Quantity 2½ pints (1.42 litres)
2½ litre.	Quantity 3¼ pints (1.85 litres)	2½ litre.	Quantity 4¼ pints (2.41 litres)

First decide what degree of frost protection is required before adding the anti-freeze to the radiator. If temperatures below 0° F. (—18° C.) are likely to be encountered at least 25 per cent. of anti-freeze should be used. Consult your local dealer for the correct quantity.

Make sure that the cooling system is watertight and examine all joints, replacing any defective rubber hose with new.

Before adding anti-freeze mixture to the radiator, it is advisable to clean out the cooling system thoroughly by draining out the water and swilling out the water passages with a hose inserted in the water filler-cap opening, keeping the drain tap open.

Avoid excessive topping-up, otherwise there is the risk of losing valuable anti-freeze, due to the expansion of the solution. Only top-up when the cooling system is at its normal running temperature.

Generally speaking, anti-freeze is not injurious to cellulose paint, provided it is wiped off in reasonable time. It must not, however, be allowed to remain on the paintwork.

