

SECTION J

THE REAR ROAD SPRINGS (1½ and 2½ LITRE)

General Description.

Section No. J.1 Removal and replacement of the rear springs.

Section No. J.2 Dismantling and reassembling the springs.

Section No. J.3 Maintenance of the rear springs.

GENERAL DESCRIPTION

The semi-elliptic leaf springs of the rear suspension are bolted to the axle by means of "U" bolts.

The seatings for the "U" bolts are fabric lined and a certain amount of rotational movement is allowed between the axle and the bolts. A hexagon dowel prevents excessive movement.

Both ends of the springs are mounted in rubber-bushed shackles and the spring leaves themselves should be lubricated every 3,000 miles (5000 km.) with oil to Ref. F (page P.2). Care must be taken to ensure that no oil finds its way onto the rubber bushes of the spring eyes.

Spring action is controlled by Girling piston-type double-acting hydraulic dampers on early models and later by telescopic dampers.

Section J.1

REMOVAL AND REPLACEMENT OF THE REAR SPRINGS

Raise the rear of the car and jack up under the rear axle so that the spring "U" bolts can be detached and the shock absorber arm freed from its mounting.

Undo the shackle bolt nuts at the rear end of the spring and remove the bolts. Repeat for the front end.

When refitting, make quite sure that the spring is the correct way round. The bolt which passes through the middle of the leaves is 23½ in. (59 cm.) from the front shackle and 22½ in. (56.5 cm.) from the rear. The front portion of the spring also has two spring clips and the rear only one.

When a spring is being refitted, always lower the car onto its wheels so that the springs are subjected to their normal load before tightening the shackle bolts. This is essential to prevent excessive wear of the bushes through greater flexing in one direction.

Section J.2

DISMANTLING AND REASSEMBLING THE SPRINGS

To dismantle the rear road springs the clamp bolts of the three spring clips should be undone and removed, after which the centre bolt may be taken out. It is advisable to clamp the leaves together while the centre bolt is released.

Clean each leaf and examine for cracks and breakage. Check the centre bolt for wear or distortion. Renew any defective or worn parts. When fitting new leaves it is important that they are of the same length, thickness and curvature as the originals.

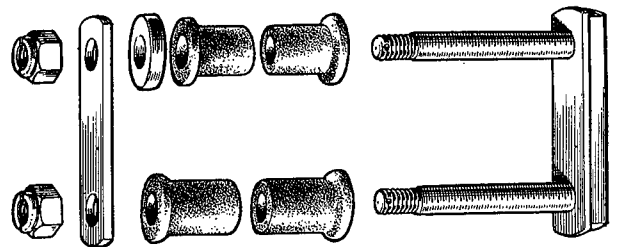

Fig. J.1.

The spring shackle and rubber bushes. Note that the distance washer is on the inside on the front shackle and on the outside on the rear shackle.

Section J.3

MAINTENANCE OF THE REAR SPRINGS

No oil or grease should be applied to the shackle bearings as they are of the flexing rubber type.

The springs themselves should be sprayed with oil every 3,000 miles (5000 km.), but care must be taken not to allow the oil to get onto the bushes.



SECTION K

THE FRONT SUSPENSION (1½ and 2½ LITRE)

General Description.

Maintenance.

- | | |
|------------------|---|
| Section No. K.1 | Removing a torsion bar. |
| Section No. K.2 | Replacing and resetting the torsion bars. |
| Section No. K.3 | Removal of the front suspension unit. |
| Section No. K.4 | To change a swivel pin assembly. |
| Section No. K.5 | To dismantle the swivel pin assembly. |
| Section No. K.6 | To remove a front hub. |
| Section No. K.7 | To dismantle the front hub. |
| Section No. K.8 | To remove the steering gearbox. |
| Section No. K.9 | To change a track-rod. |
| Section No. K.10 | To dismantle the steering gear. |
| Section No. K.11 | To dismantle the bottom strut assembly. |
| Section No. K.12 | To dismantle the upper strut assembly. |
| Section No. K.13 | Note on front suspension struts. |
| Section No. K.14 | Setting the steering stops. |

GENERAL DESCRIPTION

The independent front suspension is built up as a complete unit which is bolted to the front face of the frame.

Springing is by short torsion bars lying parallel to the frame sides and located at the front end by internally splined sleeves which carry the lower suspension struts.

At the rear the torsion bars locate in splined adjusting cams which are used for setting the suspension arms to the correct position.

The lower struts are splined to the outside of the sleeve which takes the front end of the torsion bar

and the sleeve oscillates in the front suspension cradle on large rubber bushes.

The upper struts are rubber-bushed and pivot on a fixed spindle which is held in position in the front cradle by means of retaining plates, one of which is splined internally to prevent rotation.

The outer ends of the struts carry the swivel pin bearings on rubber bushes, whilst the swivel pin itself is threaded at each end to turn in the similarly threaded bushes on the bearing.

The telescopic shock absorbers are mounted between the outer ends of the lower struts and the top of the cradle.

K THE FRONT SUSPENSION

(1½ and 2½ LITRE)

MAINTENANCE

Normal maintenance consists of lubrication of the swivel pin bearings (two grease nipples are fitted to each swivel pin assembly) and the track-rod ends.

Each grease nipple should receive two or three strokes from a hand grease gun every 500 miles (800 km.). **Do not use a high-pressure gun.**

The recommended lubricants are indicated under reference D on page P.2.

Section K.1

REMOVING A TORSION BAR

Raise the front of the car until the wheels are well clear of the ground and then disconnect the retaining plate at the rear end of the bar. Now ease the cam adjuster a small amount and take off the rubber cap at the front. Now tap the bar towards the back or the front of the car, whichever is the most convenient.

Note.—Do not scribe or punch-mark the torsion bars, and make sure they are fitted to the same side of the car from which they were removed. They are not interchangeable, and it is essential that their surfaces should be devoid of damage of any sort.

Section K.2

REPLACING AND RESETTING THE TORSION BARS

With the car jacked up, slacken the cam adjuster right back so that full adjustment will be available. Bear down very slightly on the wheel and knock the

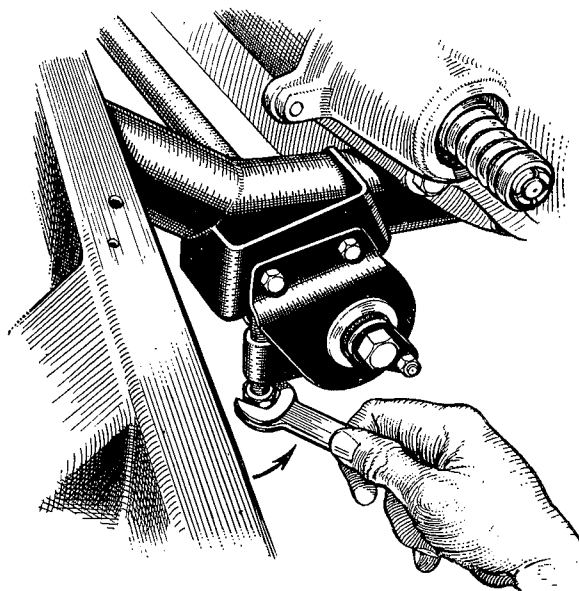

Fig. K.2.
The torsion bar adjuster.

torsion bar in from the front or rear, whichever is the most convenient. Fit the retaining plate and lock it in position.

If the special setting gauge is not available the following is the procedure for setting up the front suspension :—

Set tyre pressures to 24 lb./sq. in. (1.7 kg./cm.²).

Dimensions at "A," in the illustration K.1, should be 1½ in. (38.1 mm.) more than dimensions at "B," measurements being taken from the centres of the attachments "C" and "D" to level ground.

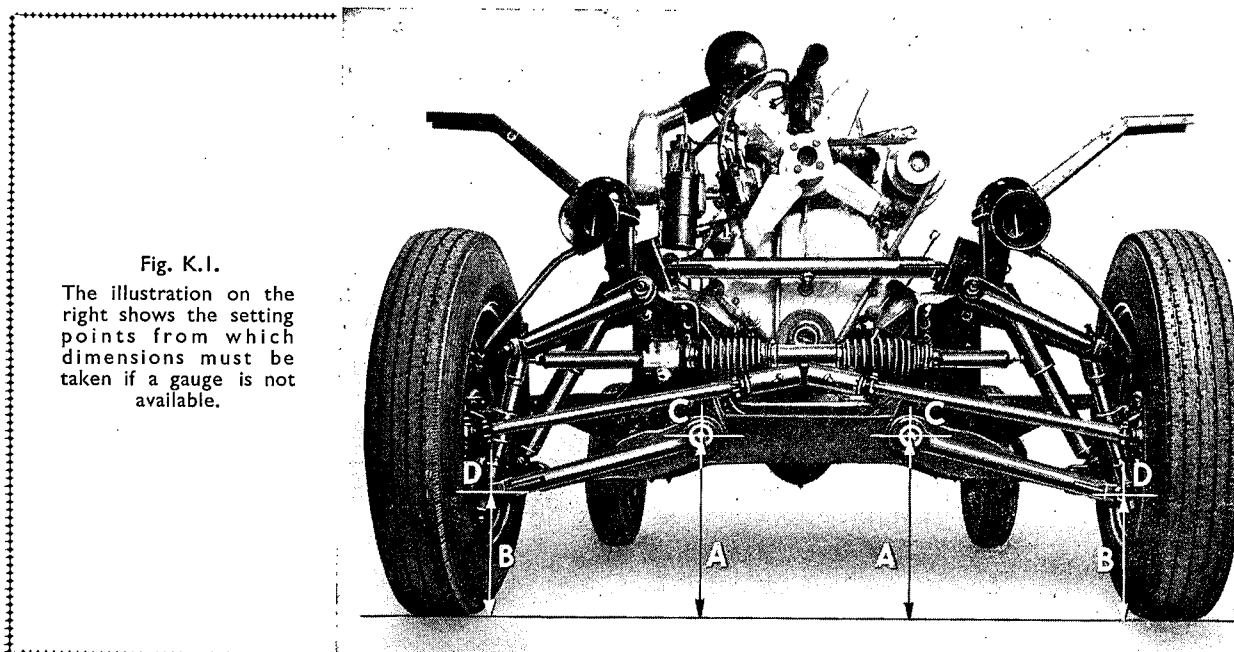

Fig. K.1.

The illustration on the right shows the setting points from which dimensions must be taken if a gauge is not available.

If this difference in height is less than 1½ in. (38.1 mm.) the dimensions must be increased, the procedure being as follows :—

The front of the car must be jacked up until the wheels are completely clear of the ground ; the weight of the car will then be removed from the suspension. This point is very important and on no account must any attempt be made to increase the dimensions at "A" with the weight of the car on its front wheels.

The adjusters at the rear ends of the torsion bars should now be screwed *in* to effect the necessary alteration in height between "A" and "B."

The car must now be lowered onto its road wheels again and the springing allowed to settle by rocking the front end up and down a few times. Dimensions "A" and "B" should now be re-checked.

If the difference between "A" and "B" is now greater than 1½ in. (38.1 mm.) there is no need to jack the car up again in order to decrease this dimension. It is only necessary to screw the adjusters *out* until the correct measurement is obtained.

Important Note.—*The track must be parallel (i.e. with no "toe-in") when the struts are set with a difference of 1½ in. (31.75 mm.) between dimensions "A" and "B." Each adjuster must then be screwed in until the 1½ in. (38.1 mm.) running setting is obtained. This will mean approximately 1½ turns on each adjusting screw. No further adjustment to the track should be made after it has been set at the 1½ in. (31.75 mm.) dimension.*

Always check the track at the same points on the wheel rims in order to allow for manufacturing tolerance. This can be ensured by marking the rims at the point where the first track measurement is taken (at axle height) and then rotating both wheels through exactly half a revolution and taking the second measurement.

Special Tool number ST.97 is also available for setting the front suspension. This tool obviates the necessity to check the dimensions given above.

Section K.3

REMOVAL OF FRONT SUSPENSION UNIT

Drain the water from the cooling system as explained under Section D.1 and then disconnect the positive battery terminal.

Take off the bonnet as described in Section D.2.

Undo the radiator steadies at the front and disconnect the radiator hoses, one at the header tank and the other at the water pump inlet.

Take off the fan blades by undoing the four screws holding them to the pulley boss.

Remove the radiator as detailed in Section D.2.

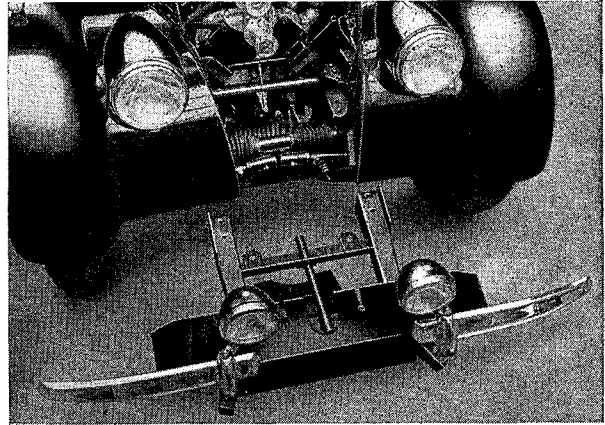

Fig. K.3.
The bumper assembly complete.

Undo the small nuts and bolts holding the piping to the radiator grille and remove the grille by undoing the two fixing nuts at the bottom and removing the two small nuts and bolts half-way up each side.

Disconnect all the electric cables at the snap connectors, marking them where necessary to prevent confusion later.

Disconnect the fog-lamps at the snap connectors under the front extension.

Remove the four bolts holding the front extension assembly to the lower edges of the wings, then take off the piping.

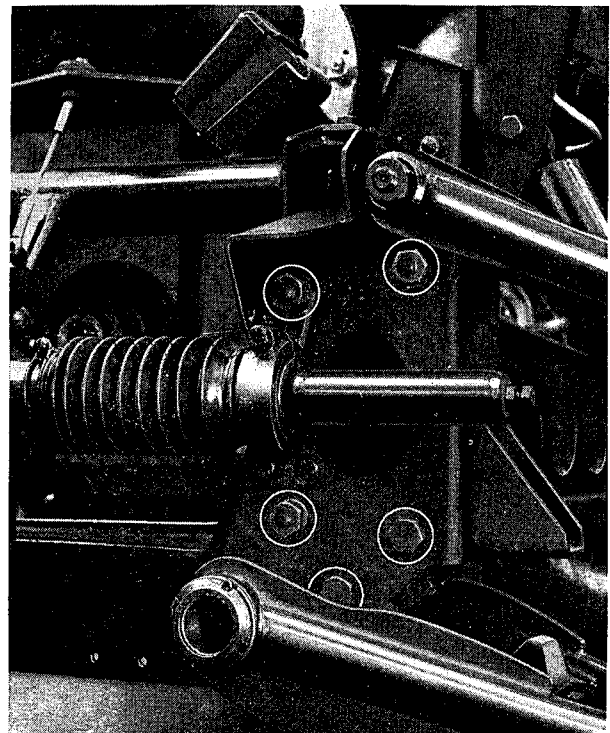

Fig. K.4.
The fixing bolts on one side are ringed.

K THE FRONT SUSPENSION

(1½ and 2½ LITRE)

Take off the front extension complete with bumpers and fog-lamps. There are four bolts each side at the top and four on the under side. The four on the under side hold the lower support, which must be bent slightly to clear as the assembly is pulled off.

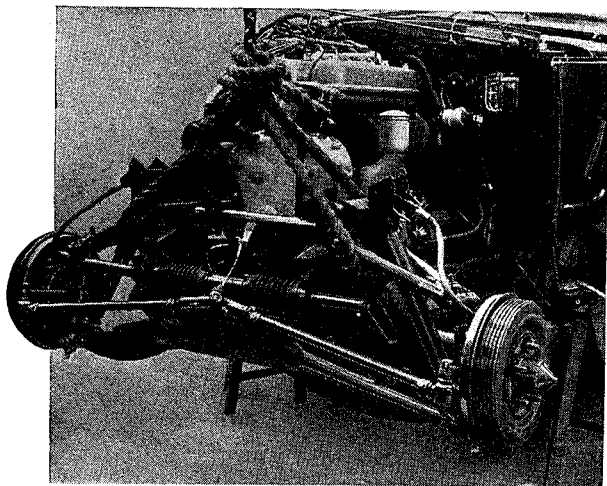

Fig. K.5.

The weight of the unit is taken on a sling.

Lift the front wheels well clear of the ground and block up the chassis underneath the forward body mounting brackets. Take off the front wheels.

Disconnect and remove both horns and then unscrew the union nut on the hydraulic pipe at its T-junction on the right-hand side of the suspension unit. Catch the fluid that escapes in a clean container.

Detach the clips holding the sidelamp cables to the wing stays and remove the latter. (Note the rubber pads at the top.)

Take off the bonnet sides.

Remove the steering column complete. (See Section R.10.)

Take off the ignition coil.

Take off the front wings. There are three bolts at the joint between the wing and the running-board and also three on each chromium strip to be undone. In addition there are four self-tapping screws that screw vertically upwards into the body. On the side opposite the steering column there is a small screw holding a mudshield to the chassis frame.

Next undo the torsion bar retainers at the rear of the bars, remove the rubber caps on the front ends of the lower strut inner sleeves, ease the adjusters slightly and tap the torsion bars rearwards until they are clear of the front cradle. **If the bars are removed completely make sure they are replaced on the same sides.**

Now disconnect the front engine steady by undoing the self-locking nut.

On the 2½ litre take off the fan pulley and bracket after releasing the split clamp, and then jack up the engine under its forward end so that the mounting bracket may be detached from the timing case. (**Note.**—There may be a certain amount of stiffness on the rubber blocks.)

On the 1½ litre jack up under the engine and remove the four engine mounting bolts.

The suspension unit should now be supported on a jack or slung from an overhead pulley so that the nuts on the ten fixing bolts can be removed.

Note that four bolts enter from the front of the unit and six from the rear.

When refitting the suspension unit, remember the four bolts with their heads facing forwards, and, if the steering gearbox has been removed, leave the clamp bolts loose so that the steering column positions the box before tightening.

Refitting the torsion bars is quite simple and they may be knocked in after the adjusters have been slackened right back to provide a full range of adjustment.

When assembly is complete, lower the car onto its wheels and set the front suspension as explained in Section K.2.

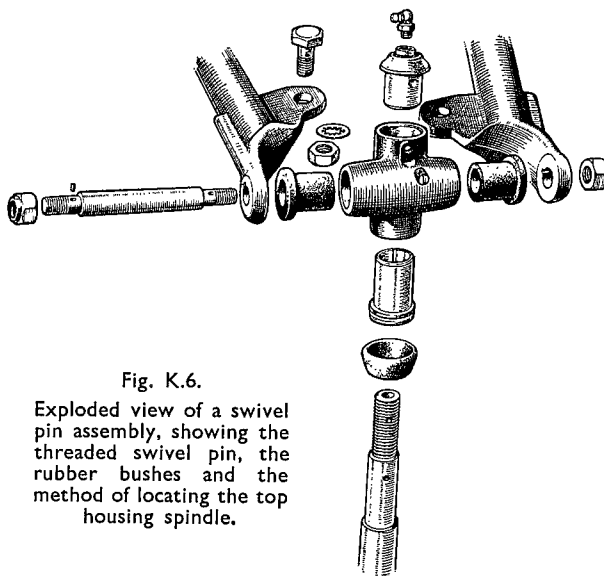

Fig. K.6.

Exploded view of a swivel pin assembly, showing the threaded swivel pin, the rubber bushes and the method of locating the top housing spindle.

Section K.4

TO CHANGE A SWIVEL PIN ASSEMBLY

Take off the road wheel.

Take off the hub and back plate as described in Section K.6 and remove the bolt which clamps the two outer ends of the upper struts. Undo the two Simmonds nuts at the front ends of the link bearing spindles. The spindles are shouldered at both ends and dowelled at the front.

Undo the nut on the front end of the spindle which carries the inner ends of the top struts. The nut is locked with a lock washer. Remove the nut and take off the front upper arm, which is rubber-bushed.

Disconnect the lower mounting for the shock absorber and detach the rebound bracket and pad.

Now remove the Simmonds nut on the front end of the lower swivel and take off the rubber cap and spring locking ring on the ring nut holding the inner end of the lower strut to the splined sleeve. Undo this ring nut with a "C" spanner. Tap the lower arm forwards and then pull the swivel pin assembly away.

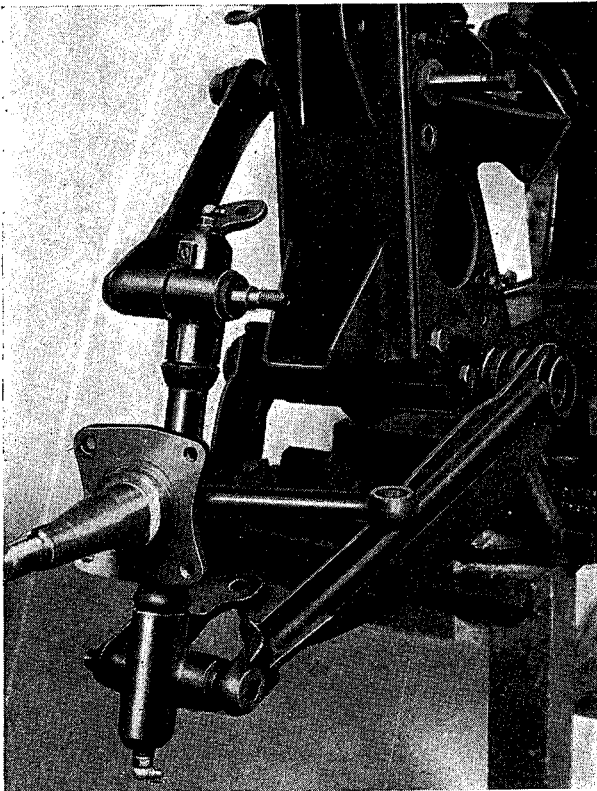

Fig. K.7.
Method of removing a swivel pin assembly.

Section K.5

TO DISMANTLE THE SWIVEL PIN ASSEMBLY

Remove the assembly as described in Section K.4. Unscrew the bearing assembly from each end of the swivel pin. The spindle bearings are rubber bushes and are easily removed.

The threaded outer bushes on the swivel bearings and the plain inner bushes are a press fit in the housing.

When reassembling, screw the bearing assemblies onto the swivel pin until they come up against the

stop and then turn them back slightly so that full movement is obtained. This will be approximately half a turn.

Note.—When refitting the swivel pin assembly to the struts make quite sure that the swivel pin lies between the link bearing spindle and the cradle at the top, whilst at the bottom it lies outside the link spindle. If this is not so the whole of the steering geometry will be incorrect.

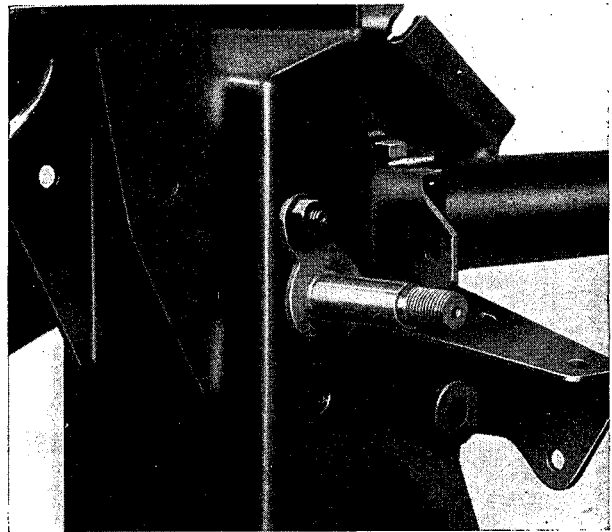

Fig. K.8.
Close-up view of a top strut swivel bearing.

Section K.6

TO REMOVE A FRONT HUB

Take off the wheel. Screw back the brake adjusters and remove the three countersunk screws holding the brake-drum to the hub. Lift off the drum.

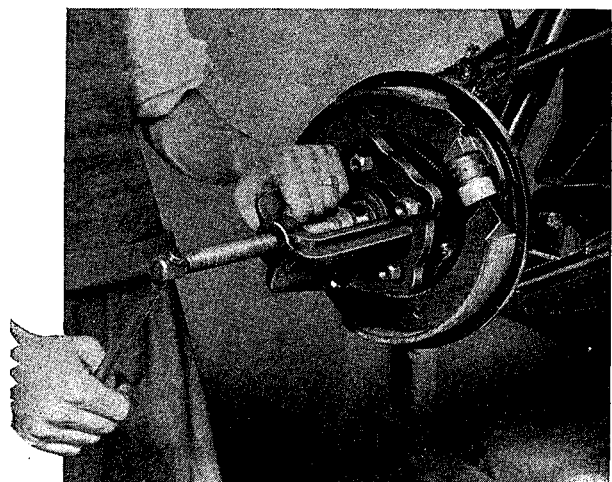
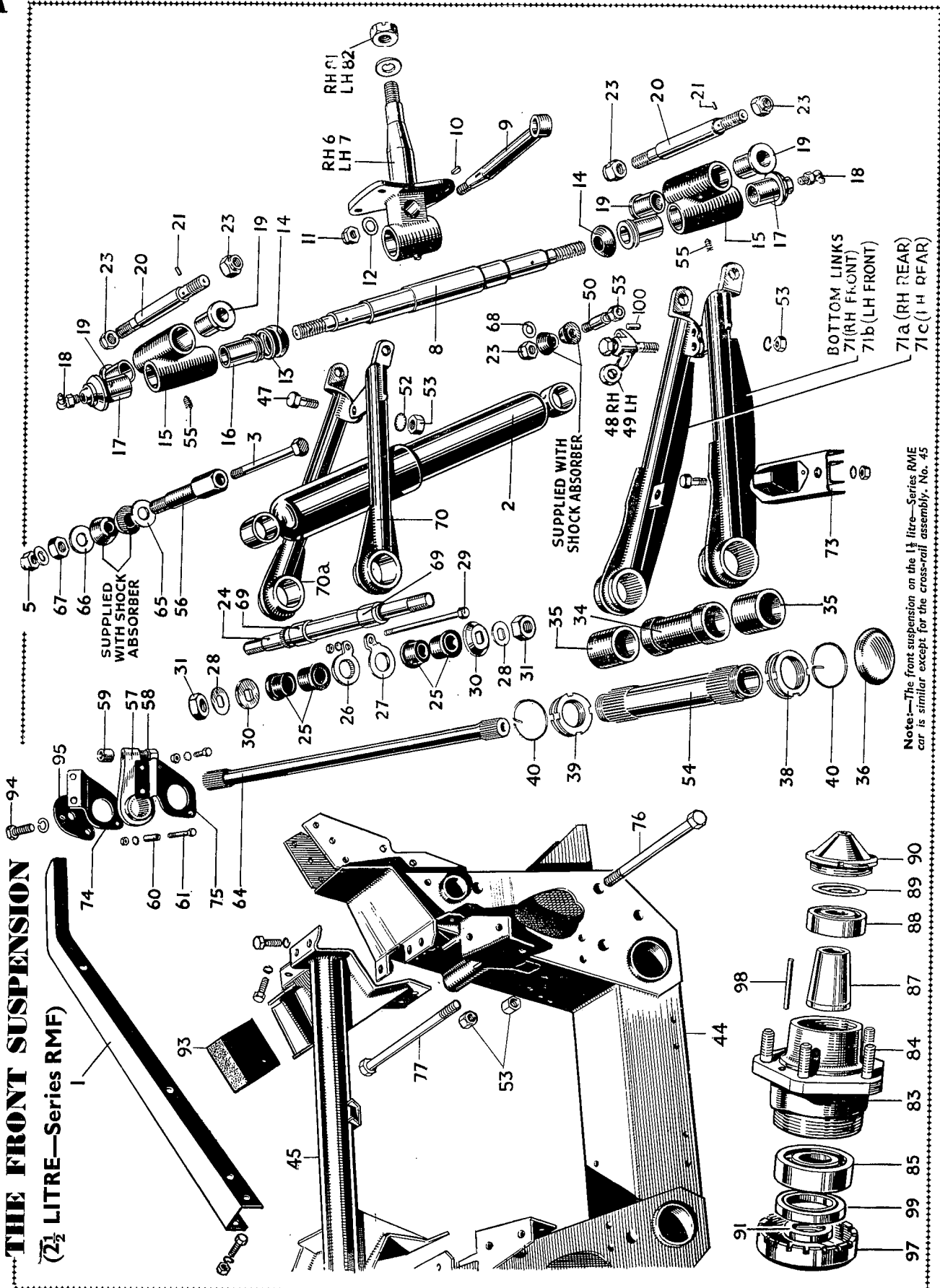

Fig. K.9.
Pulling off the front hub.



KEY TO FRONT SUSPENSION COMPONENTS (2½ LITRE—Series RMF)

No.	Description	No.	Description	No.	Description
1.	Stay—front wing.	30.	Washer—spindle.	67.	Nut—front S/A anchorage.
2.	Shock absorber—front.	31.	Locknut—spindle.	68.	Washer—front S/A bottom lug pin.
3.	Bolt—front S/A anchorage.	34.	Spacer assembly—torsion bar.	69.	Bush—top link spindle.
5.	Nut—front S/A anchorage bolt.	35.	Bush—torsion bar.	70.	Link sub-assembly—top front.
6.	Swivel—R/H.	36.	Cap—torsion bar sleeve.	70a.	Link sub-assembly—top rear.
7.	Swivel—L/H.	38.	Locknut—torsion bar sleeve.	71.	Link assembly.
8.	Pin—swivel.	40.	Spring ring—torsion bar sleeve locknut.	73.	Bracket assembly—bump restricter.
9.	Arm—swivel.	44.	Cradle assembly—front suspension.	74.	Bracket—torsion bar mounting.
10.	Key—swivel arm.	45.	Cross-rail assembly.	75.	Bracket—torsion bar mounting.
11.	Nut—swivel arm.	47.	Bolt—top link connection.	76.	Bolt (short)—cradle mounting.
12.	Washer—swivel arm.	48.	Lug—front S/A—bottom R/H.	77.	Bolt (long)—cradle mounting.
13.	Safety ring—swivel pin.	49.	Lug—front S/A—bottom L/H.	81.	Nut—swivel—R/H.
14.	Rubber cover—swivel pin bush.	50.	Pin—front S/A bottom lug.	82.	Nut—swivel—L/H.
15.	Housing—swivel pin bush.	52.	Shakeproof washer.	83.	Hub—front.
16.	Bush—plain swivel pin.	53.	Nut.	84.	Stud—wheel—front.
17.	Bush (screwed) assembly.	54.	Sleeve—torsion bar.	85.	Bearing—front hub (large).
18.	Greaser—swivel housing.	55.	Set screw—swivel bush housing.	87.	Distance bush—front hub bearing.
19.	Bush—swivel housing.	56.	Sleeve—front S/A anchorage.	88.	Bearing—front hub (small).
20.	Spindle—swivel housing.	57.	Cam—torsion bar adjuster.	89.	Washer—front hub bearing retaining.
21.	Dowel—swivel housing spindle.	58.	Bolt—cam adjusting.	90.	Cap—front hub bearing.
23.	Nut.	59.	Locating cup—cam adjusting bolt.	91.	Distance washer—front hub.
24.	Spindle—top link.	60.	Spacer tube.	93.	Block—engine mounting—front.
25.	Bush—top link.	61.	Bolt—torsion bar mounting bracket.	94.	Screw—torsion bar locking plate.
26.	Lock plate.	63.	Nut—torsion bar mounting bracket bolt.	95.	Locking plate—torsion bar.
27.	Lock plate—plain.	64.	Torsion bar.	97.	Ring—front hub bearing retaining.
28.	Tab washer—spindle.	65.	Washer—front S/A anchorage (large).	98.	Pin—front hub bearing retaining.
29.	Bolt—lock plate.	66.	Washer—front S/A anchorage (small).	99.	Oil retainer.

K THE FRONT SUSPENSION

(1½ and 2½ LITRE)

Unscrew the bearing cap with a "C" spanner and remove the split pin holding the large castellated nut.

Undo the nut and pick out the pegged washer. Use Special Tool ST.84 to draw off the hub on the 1½ litre and ST.64 for the 2½ litre.

Section K.7

TO DISMANTLE THE FRONT HUB

Remove the hub as described in Section K.6.

Knock out the pin which is used to lock the large ring nut in position and then unscrew the nut with a "C" spanner. Note the oil seal in the ring nut. If this seal is damaged or if it is removed at any time make sure that a new part is fitted.

Knock out the large bearing with a drift and a hammer. Withdraw the conical spacer and note that the small end faces outwards.

Knock out the smaller bearing. When refitting make sure that the bearings come up hard against their housings. The dished part of the large washer goes inwards. If this washer is assembled incorrectly there is a danger of the bearing disintegrating.

Position the cone-shaped distance-piece centrally before retightening and locking the large unit.

Section K.8

TO REMOVE THE STEERING GEARBOX

Take out the steering column as explained in Section R.10.

Disconnect the outer ends of the track-rods by removing the Simmonds nuts, and jar the ball ends out of their tapers.

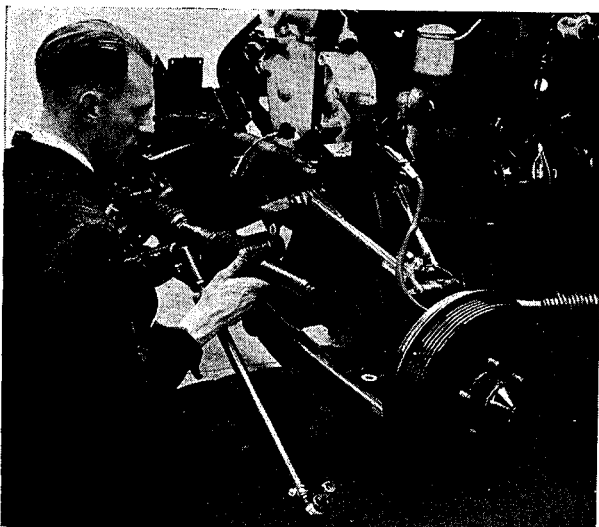

Fig. K.10.

Lifting the steering gearbox from the suspension unit.

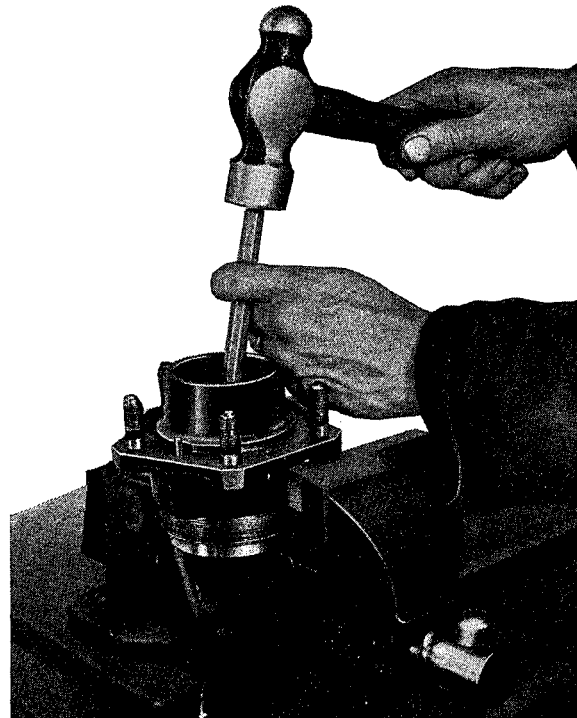

Fig. K.11.

Tapping out a front wheel bearing.

Undo the nuts on the two large bolts passing through the two mounting brackets and knock the bolts back.

Remove the four small hexagon-headed screws and lift the steering gearbox clear of the front cradle.

Section K.9

TO CHANGE A TRACK-ROD

Remove the Simmonds nuts on each ball joint and then jar the ends off the tapers so that the track-rod may be lifted away.

When refitting a new rod make sure that it is adjusted so that the front wheels are set parallel.

Section K.10

TO DISMANTLE THE STEERING GEAR

Remove the steering gearbox as described in Section K.8.

Take off the mounting bracket on the side farthest from the pinion housing. Remove the two counter-sunk locating screws in the collar, detach the rubber sleeve and knock the collar away.

Tap out the end bearing housing, which will come away complete with its spherical bush. To remove

Fig. K.12.
In this illustration is shown the rack gear with the two track-rods and their attachment.

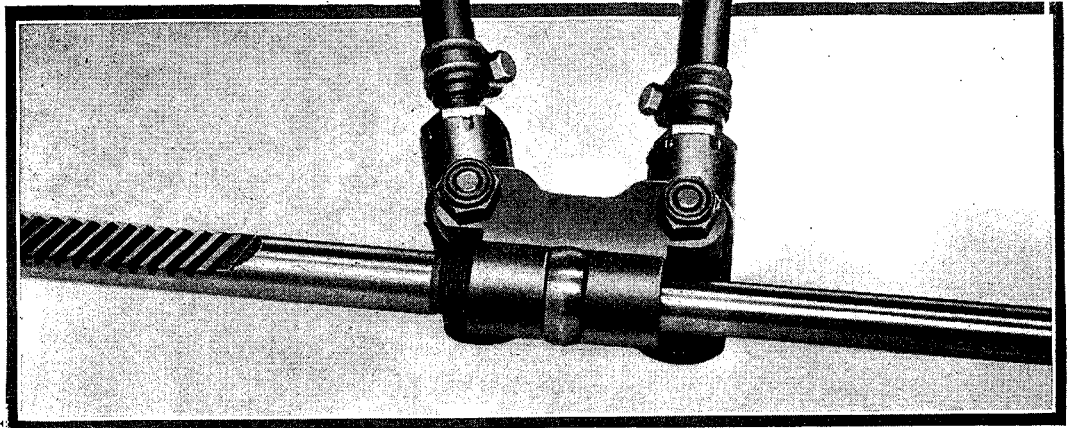

the bush, should renewal be necessary, turn it through a right angle and pull it out through the two slots.

Now remove the plunger housing complete with the plunger and spring, which is held at the foot of the pinion housing by three nuts. Note and take care of the brass shims.

To take out the pinion detach the cover which is held by three screws, take off the shims and pull the gear upwards. The bearings are of the taper roller type.

Detach the end of the rubber gaiter where it fits over the pinion housing and the rack can then be fed out of its casing by rotating the pinion until the gears are out of mesh. It will then be possible to pull the rack away complete with the double eye and both track-rods.

The rack is threaded to take the double eye and the inner spherical bearing, both of which are also threaded.

When the steering gear has been reassembled, grease to Ref. D (page P.2) should be fed in through the

plunger housing, and also via a grease nipple, which should be substituted for the stop screw located farthest from the pinion end of the assembly.

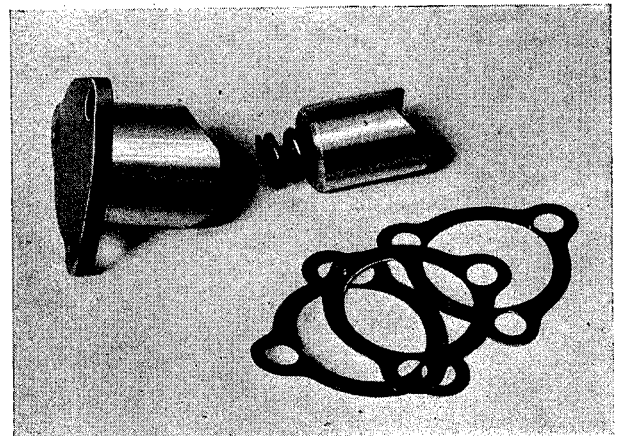

Fig. K.14.
The plunger housing.

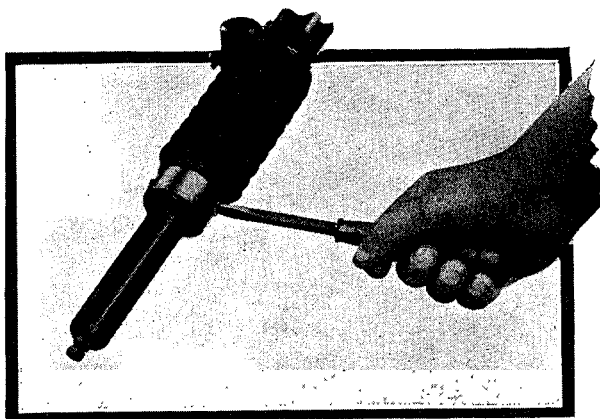

Fig. K.13.
Detaching the two countersunk screws on the locating collar.

Section K.11

TO DISMANTLE THE BOTTOM STRUT ASSEMBLY

- Jack up the car.
- Remove the front wheel.
- Remove the torsion bar. (See Section K.1.)
- Remove the bracket carrying the rubber buffer.
- Remove the lower mounting bracket for the shock absorber and take off the front Simmonds nut holding the link bearing spindle in place.
- Pick off both lock rings holding the ring nuts on the inner pivots and undo the front nut with a "C" spanner.
- Pull off the front arm.
- Unscrew the two small hexagon set screws holding the distance tube in the pivot housing.

KEY TO STEERING GEAR COMPONENTS

No.	Description	No.	Description	No.	Description
1.	Steering box.	22.	Track-rod socket housing (inner).	46.	Steering ball socket.
2.	Steering box sleeve for column.	24.	Steering ball.	47.	Inner starting joint spring stop.
3.	Steering box stud (top).	25.	Greaser.	48.	Steering box retaining ring.
4.	Steering box cover shim (steel).	26.	Track-rod end (outer).	49.	Steering box screwed plug assembly.
5.	Steering box cover shim (brass).	27.	Track-rod eye clamp.	50.	Steering stem gear.
6.	Steering box tab washer.	28.	Track-rod eye clamp bolt.	51.	Steering gear.
7.	Steering box bracket.	31.	Swivel ball.	52.	Steering gear housing and adaptor.
8.	Steering stem gear bearing and cup.	32.	Swivel ball socket.	53.	Track-rod double eye cover.
9.	Track-rod double eye.	33.	Swivel ball socket washer.	54.	Steering gear bearing housing assembly.
11.	Track-rod double eye locating ring.	34.	Swivel ball spring.	55.	Steering gear housing split collar.
12.	Steering gear dust cover.	35.	Swivel ball retainer.	56.	Steering gear housing split collar screw.
13.	Steering gear bearing.	36.	Swivel ball dust cover.	57.	Steering column bottom clamp.
14.	Steering gear stop bolt.	37.	Swivel ball rubber ring.	58.	Steering ball spring (inner).
15.	Steering gear stop bolt nut.	38.	Angle greaser.	59.	Steering ball spring (outer).
16.	Steering box solderless olive.	40.	Steering gear steady spring.	60.	Swivel steering ball nut.
17.	Steering box solderless olive nut.	41.	Steering gear steady shim (steel).	61.	Steering ball rubber cover.
18.	Steering column inner tube coupling.	42.	Steering gear steady housing.	62.	Track-rod double eye cover clip.
19.	Retainer peg.	43.	Steering gear steady.	63.	Steering column bottom clamp bolt.
20.	Track-rod.	44.	Steering gear steady shim (brass).		
21.	Track-rod end (inner).	45.	Steering box stud (bottom).		

Undo and remove the nut and bolt passing through the two lugs at the outer ends of the top arms.

Remove the front Simmonds nut on the top link bearing spindle.

Take off the top front strut and lift off the swivel pin assembly. With the lower rear strut still attached to the splined sleeve, rotate the arm so that the sleeve, rubber bushes and distance-piece are worked out of their housing.

When assembling, the distance tube and rubber bushes should be fitted to the splined sleeve and the assembly inserted in the cradle, after which the set screws for the distance-piece should be fitted.

Note that assembly will be very difficult, if not impossible, if french chalk is not used on the rubber.

The distance-piece must be fitted the correct way round, as must the splined tube, otherwise the torsion bar will not engage with the internal splines. In this case the internal splines must be nearest the rear end.

Section K.12

TO DISMANTLE THE UPPER STRUT ASSEMBLY

Remove the nut and bolt clamping the two outer ends of the struts. Take off the Simmonds nuts on the link bearing spindle.

Bend back the locking tab on each nut on the inner spindle and take off the nuts. The arms will now pull off. Note that in this case the arms themselves are rubber-bushed and the spindle is held in place by retaining plates, one of which is splined.

If this upper spindle is bent at any time it must be driven out and new bronze bushes fitted to the holes in the cradle.

Section K.13

NOTE ON FRONT SUSPENSION STRUTS

If it is necessary to change a strut or pair of struts at any time this may be done by removing, for example, the front strut and replacing it with the new one, then taking off the rear strut and fitting the replacement part at this point.

This method of substitution is much easier than allowing the swivel pin assembly to fall away.

Section K.14

SETTING THE STEERING STOPS

It is most important that the steering stops at the ends of the rack housings be correctly reset whenever they have been disturbed for greasing the steering gearbox, or for any other reason, in order to provide the greatest possible amount of lock without risk of the tyre contacting part of the chassis when the wheels are hard over.

To set the stops, jack the car so that both front wheels are clear of the ground and turn the steering wheel till the road wheels are at full lock in one direction. Check the clearance between the rear edge of the tyre on the inside of the turn and the chassis. There should not be less than $\frac{3}{4}$ in. (19 mm.) between the tyre and the nearest point on the chassis.

Any appreciable deviation from this clearance must be corrected by adjustment of the appropriate stop.

Repeat the test with the wheels on the other lock and make quite sure that the stop screw locknuts are tightened up adequately.