

SECTION B**THE FUEL SYSTEM
(2½ LITRE)**

- Section No. B.1 Removal of the fuel tank.
- Section No. B.2 Construction of the fuel pump.
- Section No. B.3 Action of the fuel pump.
- Section No. B.4 To dismantle and reassemble the fuel pump.
- Section No. B.5 Fuel pump adjustment.
- Section No. B.6 Tracing fuel pump troubles.
- Section No. B.7 Fuel pump maintenance.
- Section No. B.8 The carburetters.
- Section No. B.9 Setting the twin carburetters.
- Section No. B.10 Centring the jet.
- Section No. B.11 Sources of carburetter trouble.

Section B.1

REMOVAL OF THE FUEL TANK

Drain the tank by unscrewing the drain plug and then disconnect the fuel line and cable to the fuel gauge unit.

Disconnect the two filler neck hoses, undo the nuts at the three tank attachment points and lower the tank forwards, when it may be pulled out towards the rear of the car.

Section B.2

CONSTRUCTION OF THE FUEL PUMP

The 12-volt fuel pump is an S.U. Type L.

The pump consists of three main assemblies, the body, the magnet assembly and the contact breaker.

The body is composed of a hollow stamping or casting (8), into the bottom of which the filter (12) is screwed. The pump inlet union (29) is screwed in at an angle on one side. The outlet union (1) is screwed into the top and tightens down on the delivery valve cage (5) which is clamped between the two fibre washers (2 and 6). In the top of the delivery cage is the delivery valve, a thin brass disc (4) held in position by a spring clip (3). Inserted in the bottom of the cage is the suction valve (7), being a similar disc to (4) and resting on a seating machined in the body. Holes connect the space between the valves to the pumping chamber, with a shallow depression on the forward face of the body. This space is closed by a diaphragm assembly (9) which is clamped at its outside edge between the magnet housing (27) and body (8) and at its centre between the retaining plate and the steel armature (15). A bronze rod (16) is screwed through the centre of the armature, to which the diaphragm is attached, and it passes through the magnet core to the contact breaker, which is located at the other end. A volute spring (28) is interposed between the armature and the end plate of the coil to return the armature and diaphragm.

The magnet consists of a cast-iron pot having an iron core (17), on which is wound a coil of copper wire which energises the magnet. Between the magnet housing and the armature are fitted eleven spherical-edged brass rollers (10). These locate the armature centrally within the magnet at all times, and allow absolute freedom of movement in a longitudinal direction. The contact breaker consists of a small bakelite moulding carrying two rockers (25 and 26), which are both hinged to the moulding at one end and are connected together at the top end by two small springs, arranged to give a "throw over" action. A trunnion is fitted into the centre of the inner rocker, and the

bronze push-rod (16) connected to the armature is screwed into this. The outer rocker (26) is fitted with a tungsten point, which makes contact with a further tungsten point on a spring blade (24). This spring blade is connected to one end of the coil, and the other end of the coil is connected to the terminal (20), which also serves to hold the bakelite moulding onto the magnet housing.

A short length of flexible wire is connected to the outer rocker and to the other terminal (23) to provide the earth return when the contacts are closed.

The rocker mechanism is insulated by fibre bushes. Two fibre bushes are fitted to one of the spindles of the "throw over" mechanism in order to silence the operation of the contact breaker.

Later pumps have an alloy body, die-cast in two pieces, the joint between them being sealed by a gasket.

Section B.3

ACTION OF THE FUEL PUMP

The action of the pump is as follows:—

When the pump is at rest, the outer rocker lies in the outer position and the tungsten points are in contact. The current passes from the terminal through the coil back to the blade, through the points and to the earth return, thus energising the magnet and attracting the armature. This comes forward, bringing the diaphragm with it and sucking fuel through the suction valve into the pumping chamber. When the armature has advanced nearly to the end of its stroke the "throw over" mechanism operates, and the outer rocker flies back, separating the points and breaking the circuit. The spring (28) then pushes the armature and diaphragm back, forcing fuel through the delivery valve at a rate determined by the requirements of the engine. As soon as the armature gets near the end of this stroke the "throw over" mechanism again operates, the points again make contact, and the cycle of operations is repeated.

Section B.4

TO DISMANTLE AND REASSEMBLE THE FUEL PUMP

When a pump comes in for reconditioning the first thing to do is to determine whether it has been in contact with gum formation in the fuel, resulting in the parts in contact with the fuel becoming coated with a substance similar to varnish. These deposits also cause the eventual destruction of the neoprene diaphragm. The easiest way to identify this deposit is by the sense of smell. Place the outlet union of the

pump close to one nostril, put a finger over the other nostril and breathe. If an unpleasant, stale smell is noticed it will indicate that there is some gum present in the pump. The ordinary sharp acrid smell of petrol denotes that no gum is present.

Assuming that trouble with gum formation is indicated, the whole of the parts coming into contact with fuel will have to be dismantled, and thoroughly cleaned in methylated spirits.

To dismantle the pump

First undo the filter plug, remove the filter plug washer and the filter. The latter may be found to be clogged completely with gum. Next the inlet union and its washer should be removed, followed by the outlet union, outlet union washer, valve cage, valve cage washer and suction valve. The valve cage should then be dismantled by removing the circlip retaining

the delivery valve in place, and the valve itself can then be withdrawn.

Next undo the six screws holding the two main components of the pump together. All the components of the pump body—with the exception of the washer, but including the pump body itself—should now be washed in methylated spirits. New fibre washers should be used on replacement.

If there is no evidence of gum formation, proceed as follows :—First undo the six screws holding the two parts of the pump together. The action of the valves can then be checked by blowing and sucking in the inlet union, which will check the suction valve ; carrying out the same procedure with the outlet union will check the delivery valve. In the case of the former you should be able to blow freely but not be able to suck air back, and with the latter you should be able to suck freely and not blow air back. If these are in order it is best to leave the valves alone.

Fig. B.1.
The S.U. fuel pump.

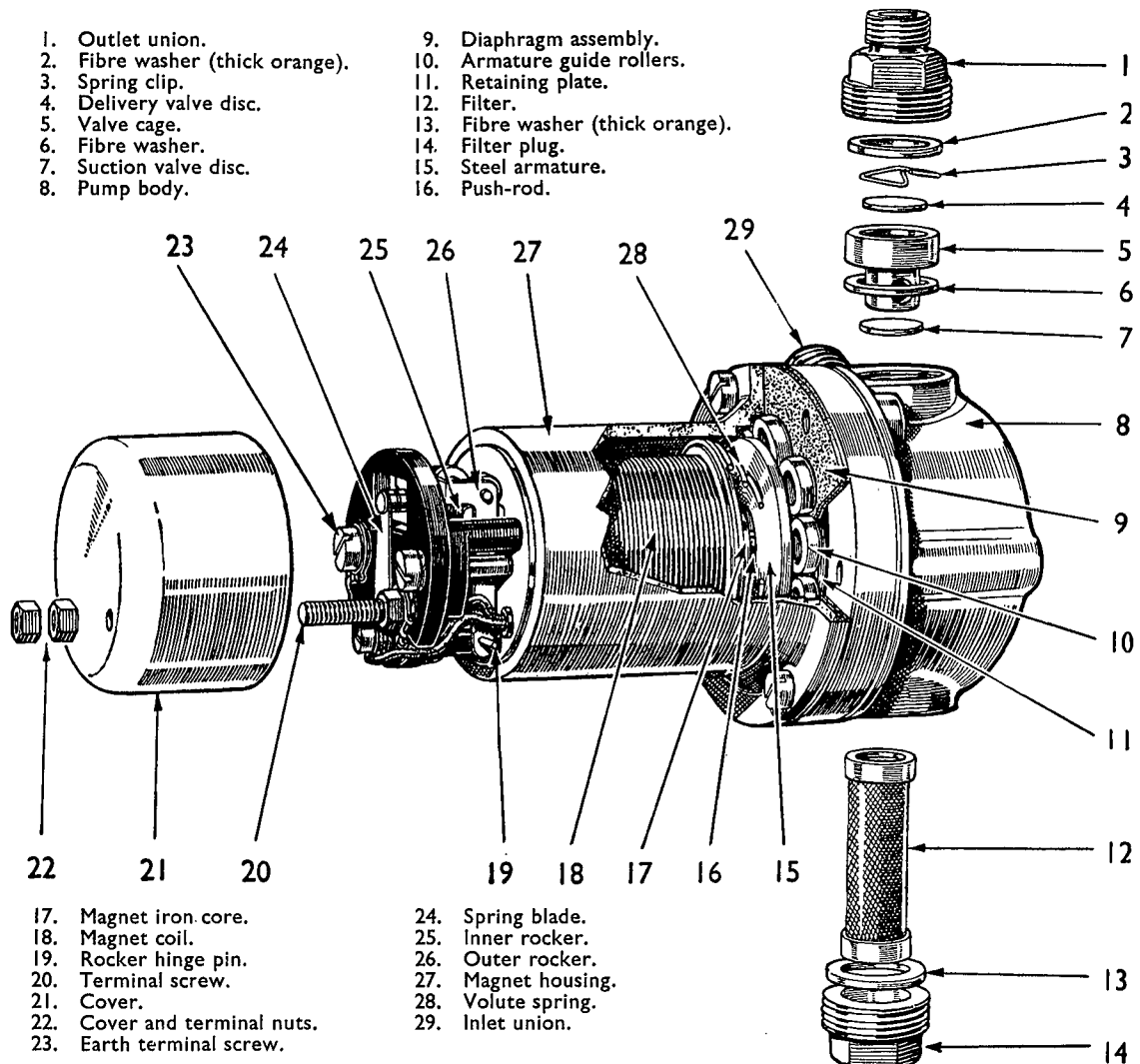

Clean the filter in fuel with a brush and swill out the body of the pump.

Next unscrew the diaphragm assembly from its trunnion in the contact breaker. This is done by rotating the whole assembly in an anti-clockwise direction. While doing this, care should be taken not to lose the brass rollers fitted behind the diaphragm. The easiest method is to hold the body in the left hand and to rotate the diaphragm.

Now remove the contact breaker cover by taking off the nut which holds it in place on the terminal, and then undo the further nut on the terminal, which acts as a seating for the cover. Beneath this will be found a lead washer which is squeezed into the thread on the terminal. This should be cut away with a pocket knife, allowing the terminal to be pushed down a short way so that the tag on the coil end is free on the terminal.

The 5 B.A. screw holding the contact blade in position should now be removed, together with its spring washer and the contact blade.

The two long 2 B.A. screws holding the bakelite pedestal in place should now be removed, together with their spring washers. This will enable the contact breaker assembly to be taken off, using great care to get the coil end tag over the terminal without damaging the coil end.

The hinge pin on which the rocker pivots can now be pushed out sideways and the pump is completely dismantled, since the rocker mechanism is not supplied in broken-down sections but only as a complete assembly.

Under no circumstances should any attempt be made to disturb the core of the magnet. The core can only be located in position correctly with special press tools, and in any case should not need to be interfered with.

To reassemble the pump

When reassembling, see that all parts are clean. The valves (4 and 7) should be fitted with the smooth side downwards. Care should be taken that the valve retaining clip (3) in the delivery valve cage (5) is correctly located in its groove. The thin hard red fibre washer (6) should be fitted under the valve cage and a thick orange-coloured one (2) above the valve cage and another thick one (13) above the filter plug. The washer on the inlet union (29) is a thick red fibre one.

The contact breaker should be assembled on its pedestal in such a manner that the rockers are free in their mountings, without appreciable side play. Any excessive side play on the outer rocker will allow the points to get out of line, while excessive tightness will make the action of the contact breaker sluggish

and interfere with its action. To obtain the required freedom in cases of tightness, it may be necessary to square the outer rocker up with a pair of thin-nosed pliers. The hinge pin is case-hardened and on no account should ordinary wire be used as a replacement. Always use the correct hardened pin.

Should the spring contact-breaker blade be removed, it should always be replaced bearing directly against the bakelite pedestal, i.e. underneath the tag.

When properly fitted the blade should rest against the ledge, formed below the opening in the pedestal for the contact points, when the points are separated and it should not be sufficiently stiff to prevent the outer rocker from coming right forward when the points are in contact. The points should make contact when the rocker is in its midway position. The most simple way to check this is to hold the blade in contact with the pedestal, taking care not to press on the overhanging portion, and see that you can get a .030 in. (.76 mm.) feeler between the white rollers and the cast-iron body of the pump (see Fig. B.2). If necessary the tip of the blade may be set to give the correct clearance.

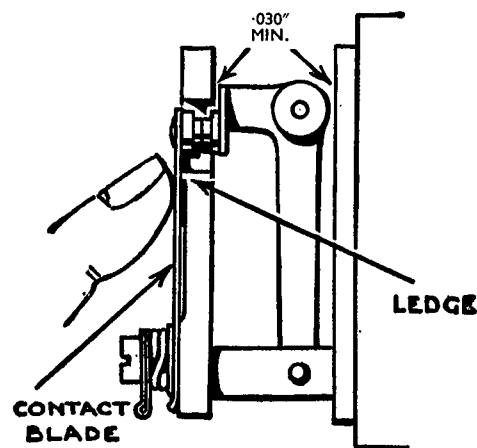

Fig. B.2.

The correct setting for the contact breaker points is clearly indicated in this illustration.

Note.—The spring washer on the B.A. screw, to which the earth connection is made, should be fitted between the tag and the pedestal. The reason for this is that the spring washer is not a reliable conductor, and the brass tag must therefore bear directly against the head of the screw.

All four connections, namely the two ends of the earthing tag and the two ends of the coil, should be soldered. The coil end leading to the terminal should be soldered to its tag and not to the retaining nut. In the case of the terminal screw which holds the bakelite cover in position, similar considerations apply,

the assembly being :—Spring washer (1), wiring tag (2), lead washer (3), and recessed nut (4), see Fig. B.3. A lead washer has been found necessary at this point as some few cases of bad connection have been found. Under no circumstances must the spring washer be omitted, or the assembly shortened in any way. Any attempt to do so is likely to lead to breakage of the pedestal when the nut retaining the cover in position is tightened up.

The armature return spring should be fitted with its larger diameter towards the coil and its smaller diameter resting against the armature. This spring must not be stretched or otherwise interfered with, or the action of the pump will be affected.

Section B.5

FUEL PUMP ADJUSTMENT

The correct adjustment for the armature, if it has been removed, is carried out as follows :—

1. Swing the contact blade on the pedestal to one side while the adjustment is being made.
2. Fit the impact washer in the armature recess.
3. Screw the armature into position.
4. Place the eleven guide rollers in position around the armature. **No jointing compound may be used on the diaphragm.**
5. Hold the magnet assembly in the left hand, in an approximately horizontal position.
6. Push the armature in with the thumb of the right hand, pushing firmly but steadily. If the contact breaker throws over, the armature should be screwed in farther until it ceases to do so ; it should then be unscrewed one-sixth of a turn

at a time, until a position is found where the contact breaker rocker just throws over, care being taken to avoid jerking the armature. It should be pressed in steadily (see Fig. B.4). The armature should then be unscrewed a further two-thirds of a turn when the setting is correct. **Do not forget that this setting must be carried out.**

When a new diaphragm is fitted, it is probable that considerable pressure will be required to push the armature right home. If there is any doubt concerning the point at which the contact breaker throws over, come back one-sixth of a turn.

7. Place the cast-iron body in position on the main body, taking care to see that the drain hole in the cast-iron body is at the bottom in line with the filter plug of the main body, and that all the rollers are still in their correct positions.

If a roller drops out of position it will get trapped between the two ports, and this will cut a hole in the diaphragm.

Make sure that the cast-iron body is seating properly on the main body, and insert the five coupling screws and the earth terminal screw. These screws should not be screwed up tightly in the first instance as it is absolutely necessary at this stage to stretch the diaphragm to its outermost position. This is best effected by using a special forked wedge to keep the armature in its extreme position (see Fig. B.5). The wedge is inserted between the white rollers of the outer rocker and pressed under the tips of the inner rocker until it lifts the

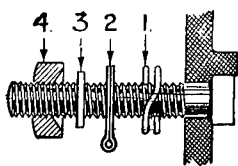

Fig. B.3.

(Above) The correct sequence of assembly of the connecting components on the terminal screw.

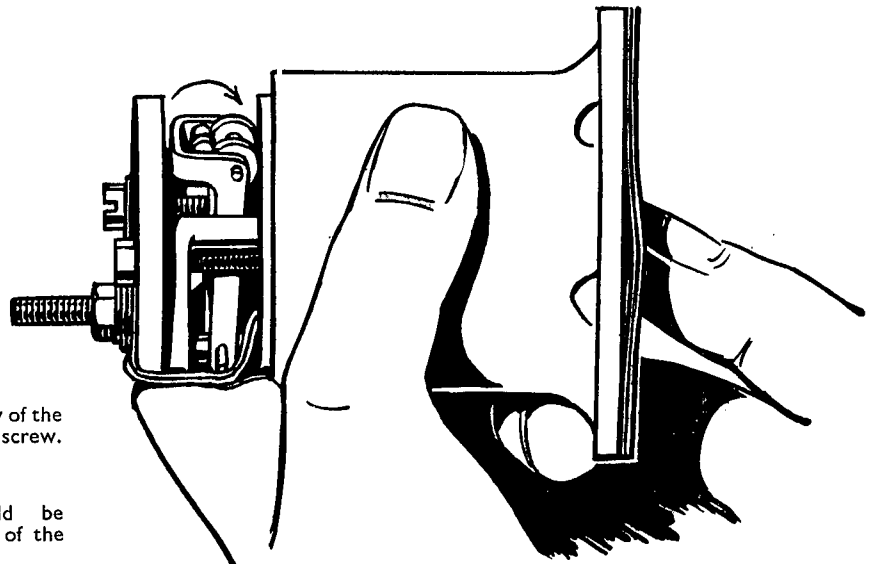

Fig. B.4.

(Right) The method which should be employed to check the correct setting of the armature.

trunnion in the centre of the inner rocker as far as it will go. If this wedge is not available the diaphragm may be stretched by holding the points in contact by inserting a matchstick under one of the white fibre rollers and passing the current through the pump. This will excite the magnet, actuate the armature, stretching the diaphragm, and the screws may then be tightened down fully while the diaphragm is held in this position.

The spring blade rests against a small projection on the bakelite moulding, and it should be so set that when the points are in contact it is deflected back from the moulding. The width of the gap at the points is approximately .030 in. (.76 mm.).

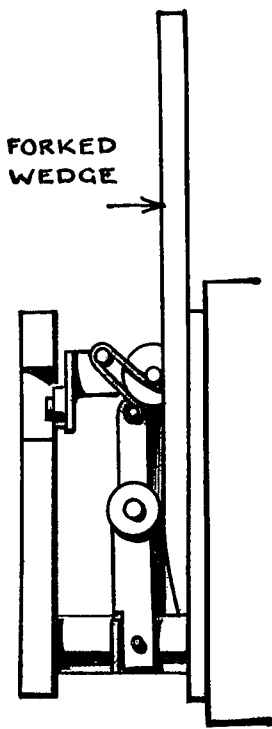

Fig. B.5.

The use of a forked wedge to keep the armature in the correct position for fitting the diaphragm.

8. The pump should now be placed on test, using a cut-away cover to enable the contact breaker action to be observed, and at the same time prevent the rocker hinge pin from falling out.

A test rig of the type illustrated in Fig. B.6 is advised. Either petrol or paraffin may be used for testing purposes, and the pump should be mounted approximately 3 ft. (91 cm.) above the test tank. The use of a glass tube and rubber connections between the pump and the test tank is advised. When the pump is switched on it should prime itself promptly, and the

paraffin, which is normally used for testing, should rise in the glass container until it flows over the top of the pipe having the $\frac{5}{32}$ in. (4 mm.) hole drilled in it 2 in. (5 cm.) below the top of the pipe. If the output of the pump is not up to normal, the $\frac{5}{32}$ in. (4 mm.) diameter hole will be able to deal with all the paraffin pumped and the liquid will not flow over the top of the pipe. If a time test is used, one pint (.57 litre) of fuel per minute should be pumped.

This, therefore, constitutes a simple form of flow-meter which establishes in a simple manner whether the pump is giving a sufficient output or not. If there is any air leak in the pump or in its connections, bubbles will be seen coming out of the pipe projecting downwards into the flow-meter. Bubbles will certainly come through here for a short while after starting up, but they should cease after the pump has been running for a minute or so. The tap should then be turned right off and the pump should stand without repeating

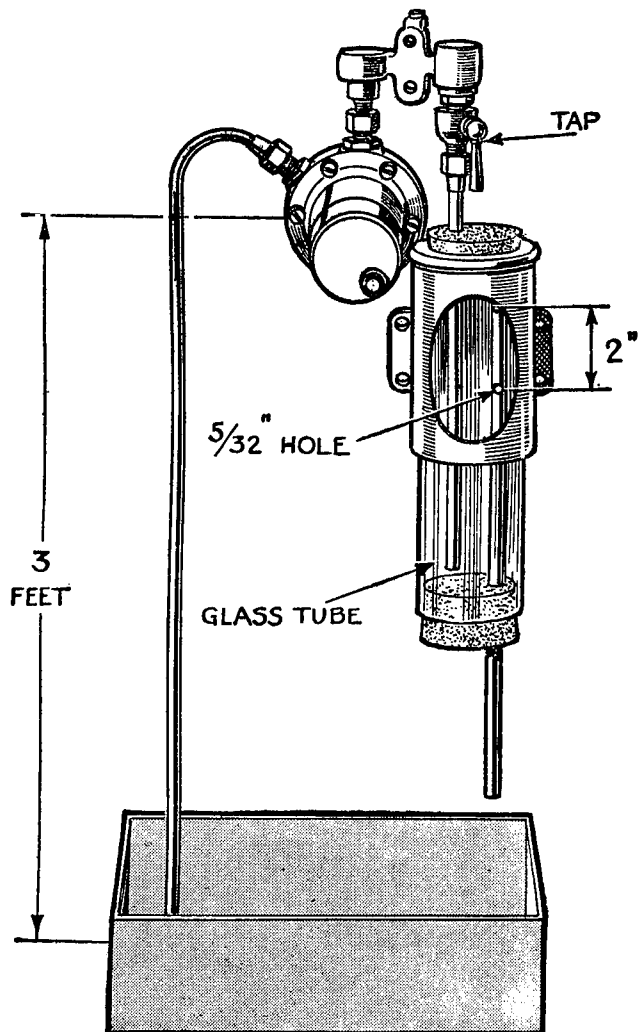

Fig. B.6.
Checking rig.

its action for at least fifteen seconds. If it repeats within this time the suction valve is not seating correctly.

The tap should then be turned on slowly to see if the pump idles satisfactorily, and that the outer rocker comes forward till it makes contact with the pedestal, and while it is in this position the tip of the blade should be pressed inwards to reduce the stroke of the pump gradually. However much this stroke is reduced the pump should go on pumping normally until it fails altogether owing to there being no gap left. If instead of pumping it buzzes, it usually indicates excessive flexibility in the diaphragm. This, of course, is not likely to be experienced with a new diaphragm. The tap should then be turned full on again and the pump tested on 9 volts and it should work satisfactorily under these conditions, although probably with a reduced output.

It is as well to let the pump run for ten minutes or so before carrying out these various tests. The cover, which is black for 12-volt, should then be fitted and held in place with an ordinary brass nut and an insulated dome nut fitted on the end of the terminal. The voltage of the pump can always be identified by the colour of the sleeving on the coil ends, this being red for 12-volt and green for 6-volt.

Note.—*There are three important points which are repeatedly overlooked by operators. These seriously affect the functioning of the pump; they are :—*

1. *To keep the contact breaker blade out of contact while obtaining the correct diaphragm setting.*
2. *To press firmly and steadily on the armature, instead of jerking it, while obtaining the setting.*
3. *Omission to stretch the diaphragm to the limit of its stroke while tightening up the body screws.*

Section B.6

TRACING FUEL PUMP TROUBLES

Should the pump cease to function, first disconnect the fuel delivery pipe from the pump. If the pump then works the most likely cause of the trouble is a sticking needle in the float-chamber of the carburetter. Should the pump not work, disconnect the lead from the terminal and strike it against the body of the pump after switching on the ignition. If a spark occurs it indicates that the necessary current is available at the terminals, and that the trouble arises with the pump mechanism. If no spark can be detected, then it is an indication that the current supply has failed and that attention should be given to the wiring and battery. If current is present, further investigation should be carried out by removing the bakelite cover which is

retained by the terminal nut. Touch the terminal with the lead. If the pump does not operate and the contact points are in contact yet no spark can be struck off the terminal, it is very probable that the contact points are dirty and require cleaning. These may be cleaned by inserting a piece of card between them, pinching them together and sliding the card backwards and forwards.

If, when the wire is connected to the terminal, and the tickler of the carburetter is depressed, the points fail to break, it is possible that there is either an obstruction in the suction pipe, which should be cleared by blowing it through with air, or some irregularity in the pump itself is preventing the correct movement. This may be due either to the diaphragm having stiffened, or to foreign matter in the roller assembly which supports the diaphragm, in which case the diaphragm should be removed and the whole assembly cleaned and reassembled in accordance with the instructions in Section B.4.

On the other hand, if the points are not making contact, see that the tips of the inner rocker (25) are in contact with the magnet housing. If they are not it is an indication that the armature has failed to return to the end of its normal travel.

To cure this, loosen the six screws which attach the magnet housing to the pump body, and make sure that the diaphragm is not sticking to the face of the magnet housing by carefully passing a penknife between the two. The hinge pin (19) should then be removed and the six retaining screws tightened up again. The tips of the inner rockers will probably now be found to be making contact with the face of the magnet housing, but if they are not, it will be necessary to remove and dismantle the whole magnet assembly in order to ascertain if an accumulation of foreign matter has caused a jam. Remember that whenever the magnet housing is removed, care should be taken to see that the guide rollers (10) do not drop out.

Pump noisy

If the pump becomes noisy and works rapidly, it is usually an indication that there is an air leak on the suction side of the pump. Check the level of the fuel in the tank and see that it is not too low.

The simplest way to test for air leakage is to disconnect the fuel pipe from the carburetter and place its end in a glass jar (approximately 1 pint or half a litre) and allow the pump to deliver fuel into it. If air bubbles appear when the end of the pipe has become submerged in the fuel it is a clear indication of an air leak on the suction side of the pump in the fuel feed pipe between the tank and the pump, which should be found and cured. Check all the

unions and joints, making sure that the filter union and inlet unions are all quite airtight.

Failure to deliver fuel

Should the pump continue beating without delivering fuel, it is probable that some dirt has become lodged under one of the valves, in which case they should be dismantled by unscrewing the top or delivery union and lifting out the valve cage, when they can be cleaned and reassembled. When replacing it see that the thin hard red fibre washer is below the valve cage and the thick orange one above.

If the pump struggles to pump and becomes very hot, it is probable that the filter has become clogged or there is an obstruction on the suction side. The filter is readily removed for cleaning by unscrewing its retaining plug at the bottom of the pump.

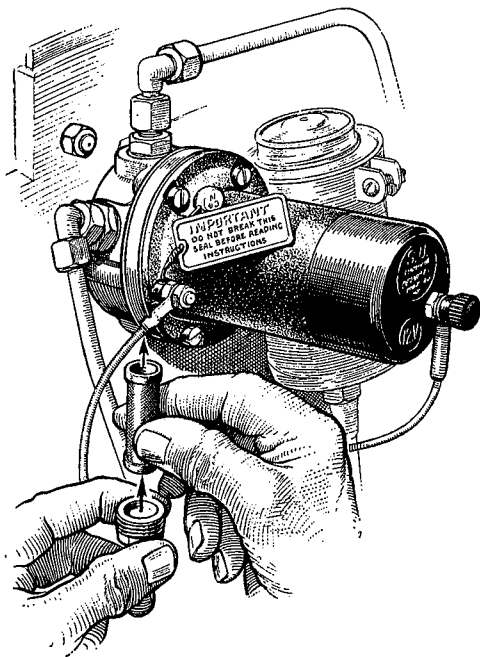

Fig. B.7.
The fuel pump filter.

Section B.7

FUEL PUMP MAINTENANCE

Apart from keeping the contacts clean, the terminals tight, and removing the filter at regular intervals for cleaning, there is no maintenance required on the fuel pump.

The filter can be removed by unscrewing the hexagon plug at the bottom of the pump, when it can be cleaned in fuel with a stiff brush. Never use rag to clean a filter.

It is important that the terminals attaching the pump leads to the pump cover and body should always be tight, the earth lead which is attached to one of the pump body flange bolts in particular.

A large percentage of the troubles encountered with electric pumps is caused by bad earth connections.

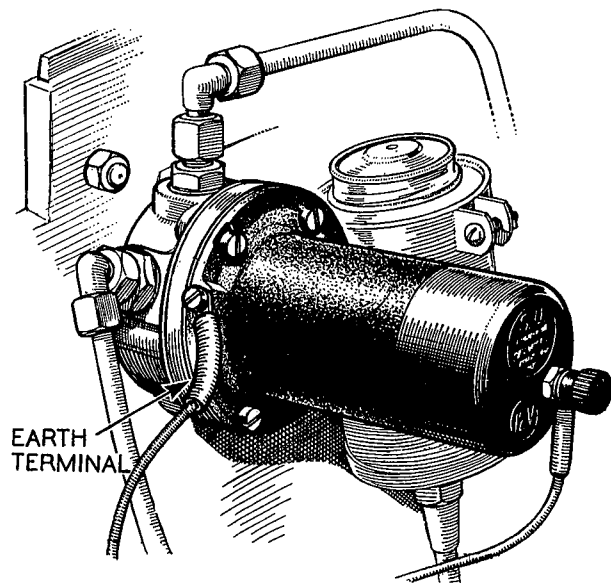

Fig. B.8.
Keep the earth terminal tight.

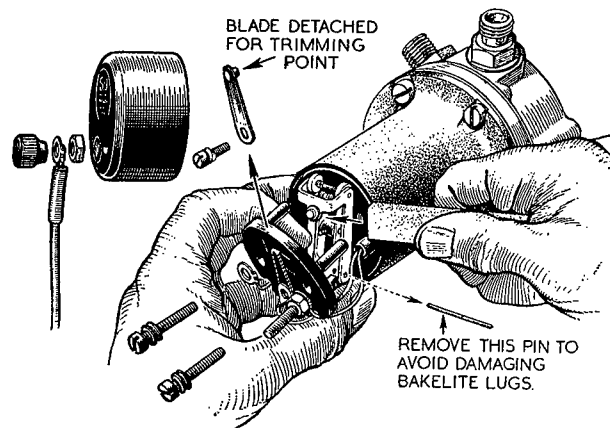

Fig. B.9.
The breaker points can be cleaned with carborundum stone.

Section B.8

THE CARBURETTERS

Two S.U. carburetters of the controllable jet type, complete with an air cleaner, are fitted. They are synchronised and careful setting is needed to produce the best results. The throttle butterflies are interconnected by means of a spindle and two universal joints.

spindle should be undone and the mixture control disconnected at either of the two jet levers. This is done by removing the clevis pin attaching the control to one of the jet levers.

Remove the air cleaner and intake elbow and then unscrew both throttle stop screws until they will just hold a piece of thin paper between themselves and the stops. Then screw each one in a complete turn.

The suction chambers should then be lifted off and

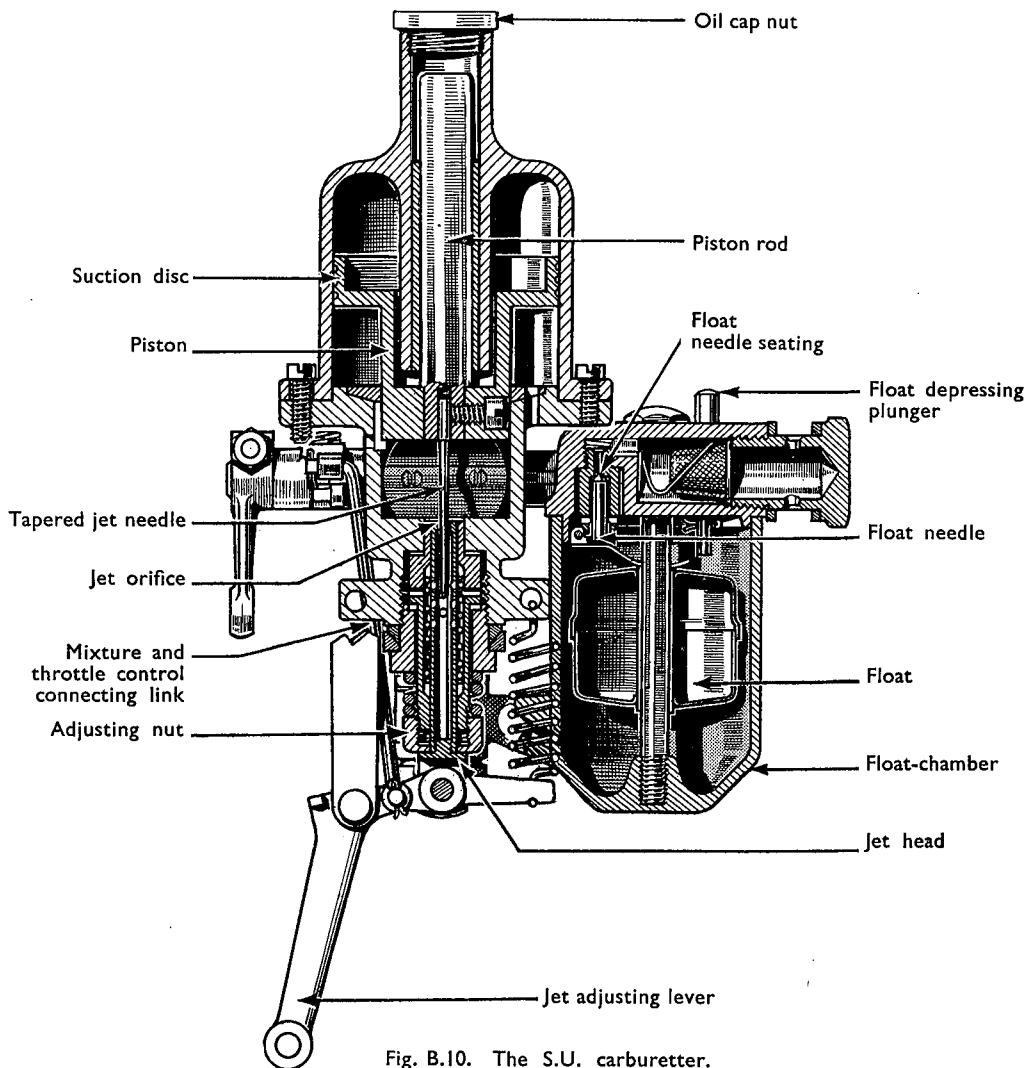

Fig. B.10. The S.U. carburetter.

Section B.9

SETTING THE TWIN CARBURETTERS

When setting the carburetters the first thing to do is to make quite sure the carburetter pistons are free and that the jets are correctly centred (explained under Section B.10).

Next, one of the clamping bolts on either of the two flexible couplings on the throttle interconnecting

the jet needles inspected for correct positioning in the piston. Also see that each jet is the same distance below the bridge on each carburetter when the jets are pushed hard up against the adjusting nuts.

The engine should now be started, and when really warm the speed should be set by turning each throttle stop screw exactly similar amounts. The direction will depend upon whether the engine speed needs increasing or decreasing. Turning the screws clockwise increases the engine speed, and vice versa.

KEY TO THE CARBURETTORS AND INDUCTION SYSTEM (2½ LITRE)

No.	Description	No.	Description
1.	Pipe—induction.	21.	Manifold—air silencer.
2.	Washer—induction pipe.	22.	Silencer—air.
3.	Rubber ring—induction pipe.	23.	Stud—air silencer manifold.
4.	Rubber ring—induction pipe.	24.	Set screw—air silencer manifold.
5.	Plug—induction pipe—hot-spot.	25.	Nut—air silencer manifold stud.
6.	Washer—induction pipe—hot-spot.	27.	Clip assembly—air silencer.
7.	Tap—induction pipe plug drain.	28.	Connection—air silencer manifold.
8.	Washer—induction pipe plug.	29.	Grommet—air silencer.
9.	Plug—induction pipe (front).	30.	Bolt—air silencer clip.
9A.	Plug—induction pipe (rear).	32.	Nut—air silencer clip bolt.
10.	Washer—induction pipe gas plug.	33.	Lever—bell crank.
11.	Carburettor (front).	36.	Rod—throttle control.
11A.	Carburettor (rear).	37.	Anchor plate—throttle return spring.
12.	Gasket—carburettor.	38.	Spring—throttle return.
13.	Stud—induction pipe.	39.	Ball joint—throttle rod.
14.	Stud—induction pipe.	40.	Nut—throttle rod ball joint.
15.	Stud—induction pipe.	41.	Pin—choke control cable (inner).
17.	Nut—induction pipe stud.	42.	Pin—choke control cable (outer).
18.	Stud—carburettor.	43.	Washer—choke control cable pin.
20.	Nut—carburettor stud.	44.	Nut—choke control cable pin.
		26.	Manifold—air silencer.
		27.	Silencer—air.
		28.	Stud—air silencer manifold.
		29.	Set screw—air silencer manifold.
		30.	Nut—air silencer manifold stud.
		31.	Clip assembly—air silencer.
		32.	Connection—air silencer manifold.
		33.	Grommet—air silencer.
		34.	Bolt—air silencer clip.
		35.	Nut—air silencer clip bolt.
		36.	Lever—bell crank.
		37.	Rod—throttle control.
		38.	Anchor plate—throttle return spring.
		39.	Spring—throttle return.
		40.	Ball joint—throttle rod.
		41.	Nut—throttle rod ball joint.
		42.	Pin—choke control cable (inner).
		43.	Pin—choke control cable (outer).
		44.	Washer—choke control cable pin.
		45.	Nut—choke control cable pin.
		46.	Screw—choke control cable pin.
		47.	Arm—throttle control wire.
		48.	Lever assembly—hand throttle control.
		49.	Adjusting screw on lever bridge piece.
		50.	Spring—adjusting screw.
		51.	Set screw—throttle wire grip.
		52.	Clip—choke control cable.
		53.	Nut—choke control cable clip screw.
		54.	Screw—choke control cable clip.
		55.	Pipe—petrol (carburettor to flexible pipe).
		56.	Lever—on carburettor spindle.
		57.	Screw—stop and adjusting.
		58.	Coupling—connecting rod.
		59.	Disc—connecting rod (steel).
		60.	Rod—throttle (linking carburettors).
		61.	Stop—hand throttle control lever assembly.
		62.	Bolt—coupling.
		63.	Nut—coupling bolt.
		64.	Gas plug—induction pipe—drain tap.

Synchronisation of the carburetters must now be checked; the best method is to listen to each intake with a piece of rubber tube in the same manner as a stethoscope.

Make sure the tube is held at the same point on each carburetter and set the throttle adjusting screw on each until the hissing noise heard is equal in both carburetters.

The next step is to adjust the mixture by screwing the jet adjusting nuts up or down by equal amounts, making sure that the jets are hard against the adjusting nuts at all times.

The engine speed will vary when this is being done, and the jets should be set so that the engine runs at the best possible speed for this setting of the throttle stop screws. Final corrections to the slow-running should then be made on the throttle stop screws, taking care to turn each an exactly equal amount.

When the mixture is correct on both carburetters the engine beat will become irregular if one of the pistons is raised slightly (approximately $\frac{1}{32}$ in. or .8 mm.).

If the piston on one carburetter is raised and the engine stops, and lifting the piston of the other does not stop the engine, then this indicates that the mixture on the first carburetter is weaker than that on the other. Further jet adjustments must therefore take place to correct this.

Correct mixture is indicated by a regular, even exhaust beat. (An irregular beat with a splashy misfire and colourless exhaust indicates a weak mixture, whilst too rich a mixture produces a rhythmic misfire or "hunting" and a blackish exhaust.)

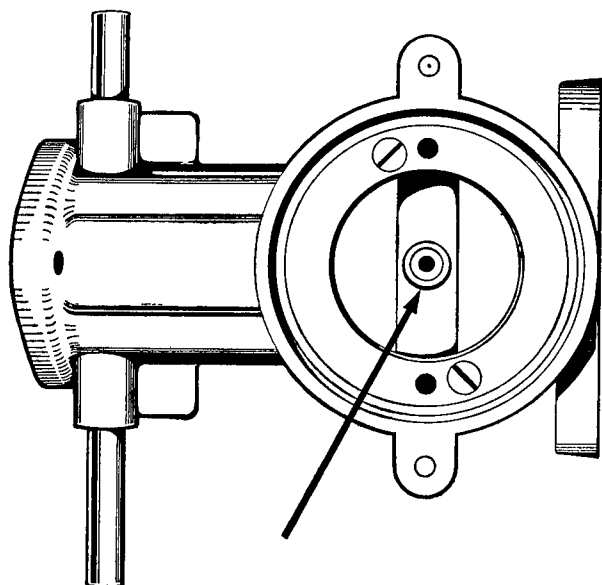

Fig. B.11.

Indicates an incorrectly centred jet which is eccentric to the jet aperture in the carburetter body.

With the jets hard up against the adjusting nuts, the mixture control linkage should be adjusted to fit the jet actuating levers exactly without disturbing their position, after which the throttle interconnecting spindle clamping bolt should be tightened.

The carburetters are now set correctly.

Section B.10

CENTRING THE JET

First remove the clevis pin at base of the jet, which attaches the jet head to the jet operating lever; withdraw the jet completely, and remove the adjusting nut and the adjusting nut spring. Replace the adjusting nut without its spring and screw it up to the highest position. Slide the jet into position until the jet head is against the base of the adjusting nut. When this has been done, feel if the piston is perfectly free by lifting it up with the finger with the dashpot piston removed. If it is not, slacken the jet holding screw and manipulate the lower part of the assembly, including the projecting part of the bottom half jet bearing, adjusting nut and jet head. Make sure that this assembly is now slightly loose. The piston should then rise and fall quite freely as the needle is now able to move the jet into the required central position. The jet holding screw should now be tightened and a check made to determine that the piston is still quite free. If it is not found to be so, the jet holding screw should be slackened again and the operation repeated. When complete freedom of the piston is achieved the jet adjusting nut should be removed, together with the

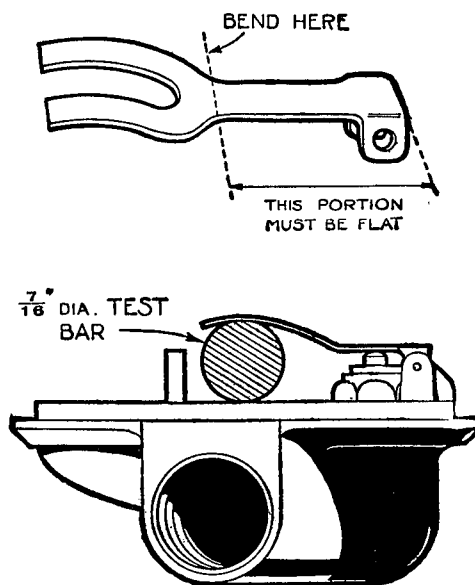

Fig. B.12.

Showing the place where the float lever should be set and the method of checking the correct adjustment of the lever.

jet, and the spring replaced. The adjusting nut should now be screwed back to its original position.

Experience shows that a large percentage of carburetters returned for correction have had jets removed and not correctly centred on replacement.

Section B.11

SOURCES OF CARBURETTER TROUBLE

Piston sticking

The piston assembly comprises the suction disc and

in the air intake and lifting the piston, which should come up quite freely and fall back smartly onto its seating when released.

Water or dirt in the carburetter

When this is suspected, lift the piston with a pencil. The jet can then be seen. Flood the carburetter by depressing the float depressing plunger and watch the jet; if the fuel does not flow through freely there is a blockage. To remedy this, start the engine, open the throttle, and block up the air inlet momentarily

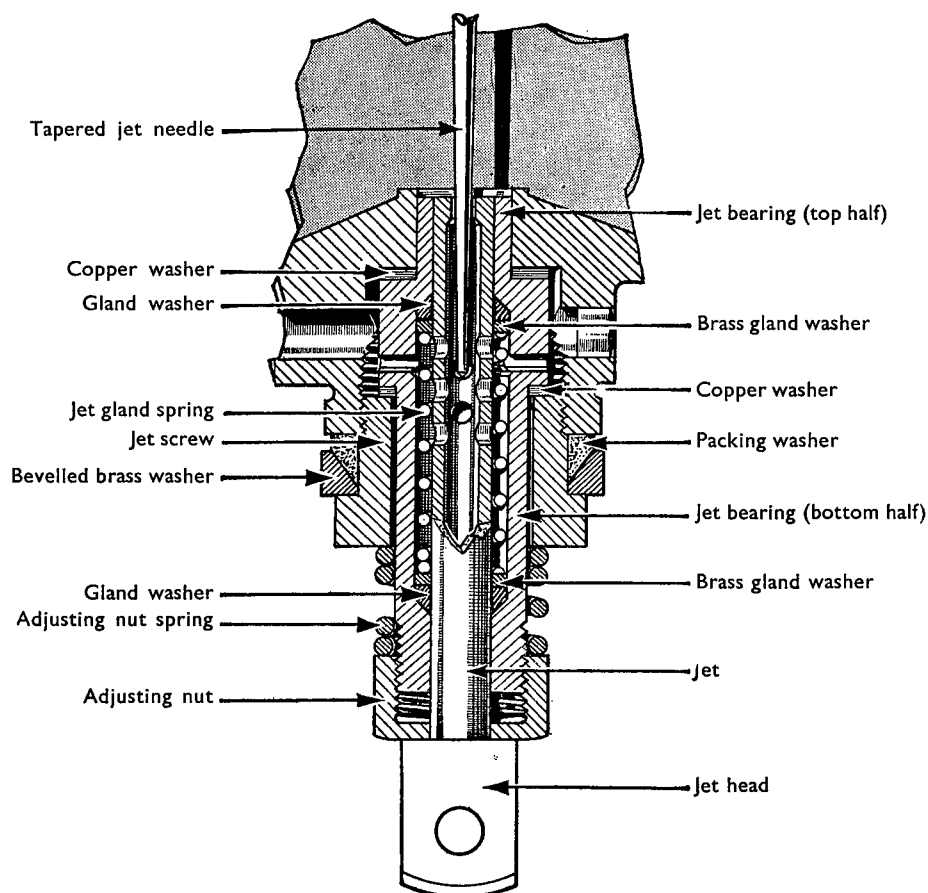

Fig. B.13.

An enlarged view of the jet assembly, showing its component parts.

the piston forming the choke, into which is inserted the hardened and ground piston rod which engages in a bearing in the centre of the suction chamber and in which is, in turn, inserted the jet needle. The piston rod running in the bearing is the only part which is in actual contact with any other part, the suction disc, piston, and needle all having suitable clearances to prevent sticking. If sticking does occur the whole assembly should be cleaned carefully and the piston rod lubricated with a spot of thin oil. No oil must be applied to any other part except the piston rod. A sticking piston can be ascertained by inserting a finger

without shutting the throttle, keeping the throttle open until the engine starts to race. This trouble seldom arises with the S.U. carburetter owing to the size of the jet and fuel ways. When it does happen the above method will nearly always clear it. Should it not do so, the only alternative is to remove the jet. This, however, should on no account be done unless it is absolutely necessary, as it has to be carefully centred when refitting and it is practically impossible to assemble this part correctly unless it is first thoroughly understood how to carry this out. (See Section B.10.)

B THE FUEL SYSTEM

(2½ LITRE)

Float-chamber flooding

This can be seen by the fuel flowing over the float-chamber and dripping from the air inlet, and is generally caused by grit between the float-chamber needle and its guide. This can usually be cured by depressing the float depressing plunger to allow the incoming flow of fuel to wash the grit through the guide and into the float-chamber.

Float needle sticking

If the engine stops, apparently through lack of fuel, when there is plenty in the tank and the pump is working properly, the probable cause is a sticking float needle. An easy test for this is to disconnect the

pipe from the electric pump to the carburettor ; switch on the ignition to check if fuel is delivered ; if it is, starvation has almost certainly been caused by a float needle sticking to its seating, and the float-chamber lid should therefore be removed, the needle and seating cleaned, and refitted. At the same time it will be advisable to clean out the entire fuel feed system, as this trouble is caused by foreign matter in the fuel, and unless this is removed it is likely to recur. It is of no use whatever renewing any of the component parts of the carburettor, and the only cure is to make sure that the fuel tank and pipe lines are entirely free from any kind of foreign matter or sticky substance capable of causing this trouble.

NOTE : For carburettor adjustments see Section BB.2

